

# Engineered Glass Seals for SOFCs

**Edgar Lara-Curzio**  
Materials Science & Technology Division  
Oak Ridge National Laboratory

13<sup>th</sup> Annual SECA Workshop  
July 25, 2011

# Acknowledgments

Amit Shyam, Rosa M. Trejo, Melanie Kirkham, Valerie Garcia-Negron, Dana McClurg, Beth Armstrong (ORNL).

Matt Chou, Jeff Stevenson, Moe Khaleel et al. (PNNL)

SECA Industry Teams

This research was sponsored by the US Department of Energy, Office of Fossil Energy, SECA Core Technology Program at ORNL under Contract DEAC05-00OR22725 with UT-Battelle, LLC.

Special thanks Rin Burke, Briggs White and Travis Shultz for guidance and support.

# Outline

- Background
- Multicomponent Silicate Glasses
- Engineered Glass Seals
- Summary and Future Work

# Background

## Requirements for SOFC seals

- Simultaneous fulfillment of thermal, physical, chemical, mechanical and electrical property requirements.
- Phase stability and chemical compatibility without substantial property degradation for 40,000 hours in oxidizing and wet reducing environments.

## Objective

- To characterize the evolution of microstructure and properties of candidate crystallization-resistant glasses for SOFC sealing applications as a function of time of exposure to SOFC relevant environments.
- To develop engineered glass seals for SOFCs.

# Multicomponent silicate glasses

Two multicomponent silicate glasses are being characterized

- SCN (SEM-COM Co. Inc., Toledo, OH 43623)
- G6 (Whatman, Piscataway, NJ 08855 )

## Mechanical and Thermophysical Properties

- Elastic constants
- Thermal expansion
- Glass transition temperature
- Viscosity
- Chemical Composition
- Phase Analysis
- Wetting Behavior (alumina, zirconia)
- Microstructure
- Porosity and its evolution
- Rates of crystallization

# Experimental

cold compressed  
glass powders

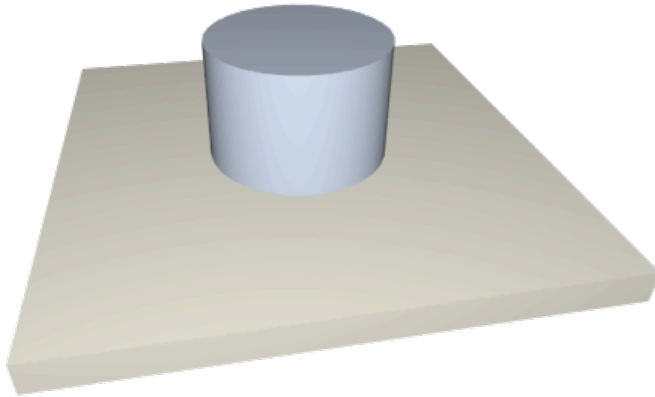

after sintering in air  
for 2 hours at 850°C

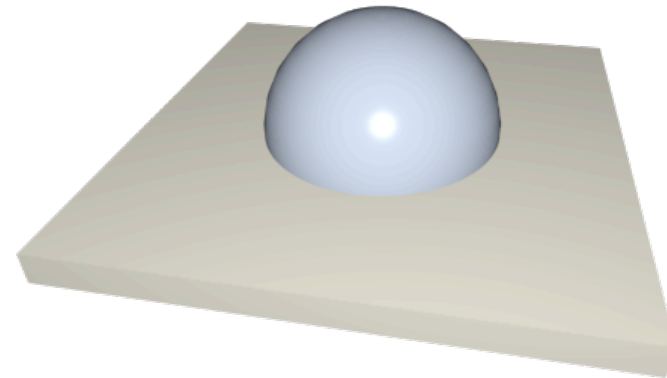

$\text{Al}_2\text{O}_3$  or 8YSZ  
substrates

# Experimental (cont.)

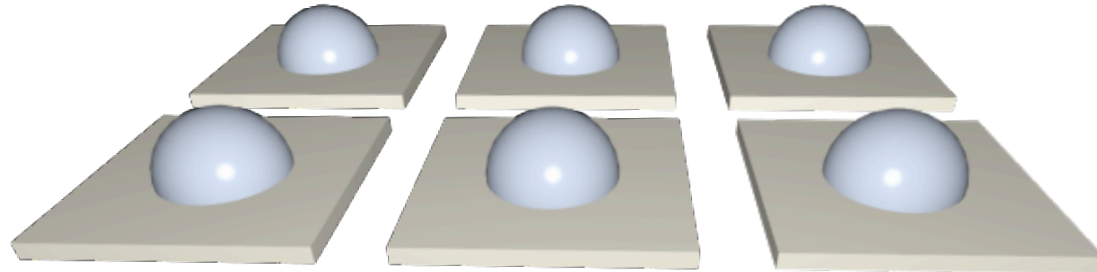

- Test specimens are exposed at 850°C to
  - **air**
  - gas mixture of **H<sub>2</sub>+N<sub>2</sub>+H<sub>2</sub>O**
- Test specimens are retrieved from the furnace every 1,000 hrs for non-destructive examination.

# Experimental (cont.)

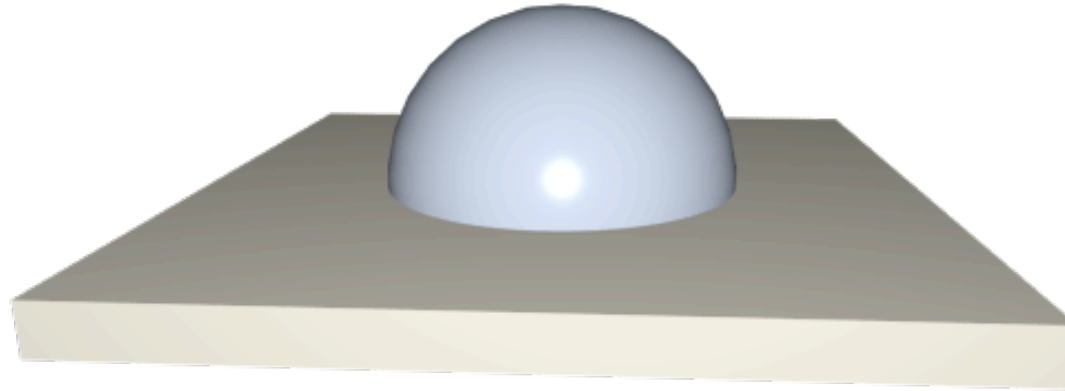

- Scanning electron microscopy
- EDS
- X-ray diffraction
- Dimensions



# Experimental (cont.)

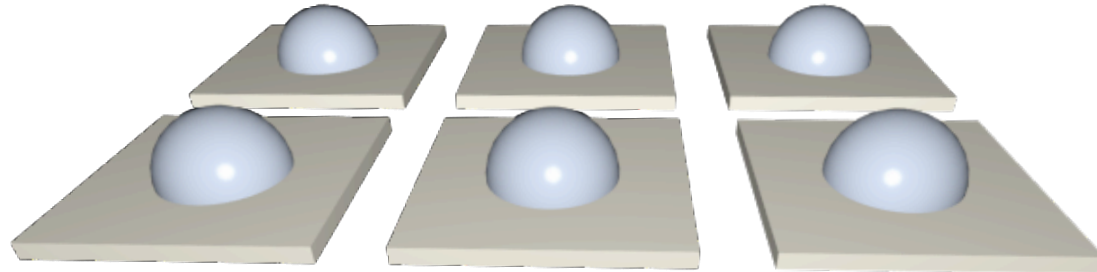

- Test specimens are exposed to **air** or a gas mixture of  $\text{H}_2+\text{N}_2+\text{H}_2\text{O}$  at  $850^\circ\text{C}$ .
- Test specimens are retrieved from the furnace every 1,000 hrs for non-destructive examination (SEM, XRD). Then they are returned to furnace to continue exposure.
- After predetermined periods of time, test specimens are removed for destructive examination (SEM, XRD, Tg, viscosity)

# Experimental (cont.)

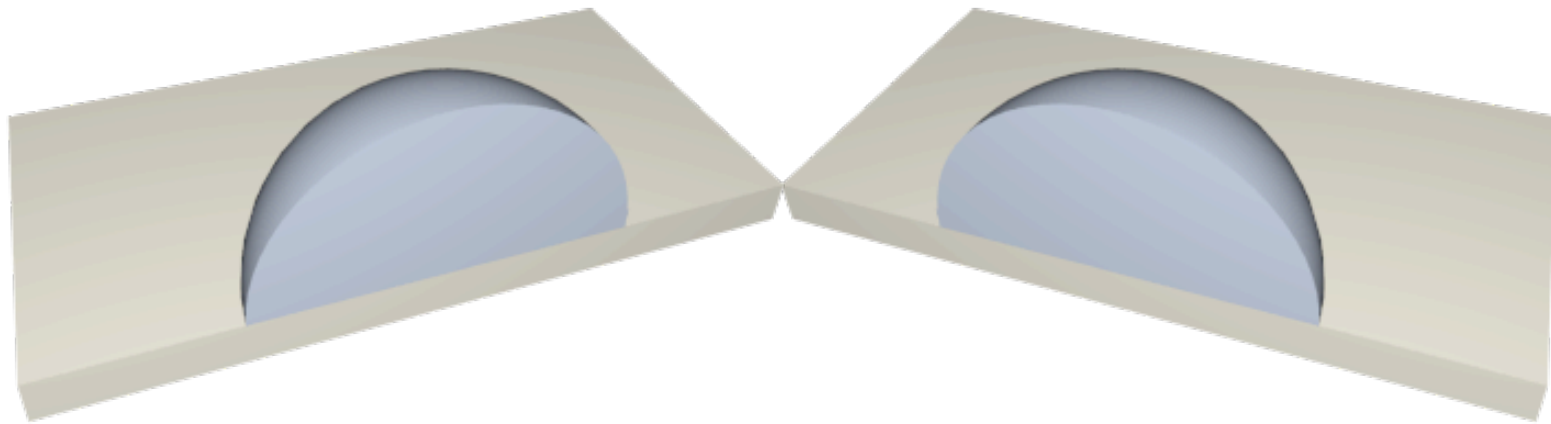

# Experimental (cont.)

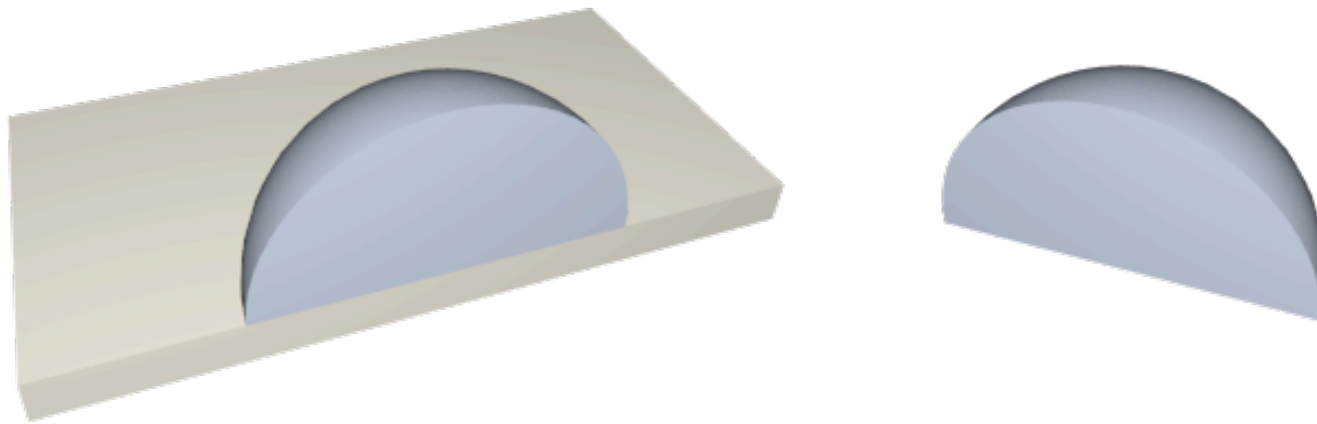

# Experimental (cont.)

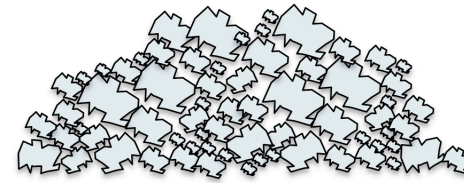
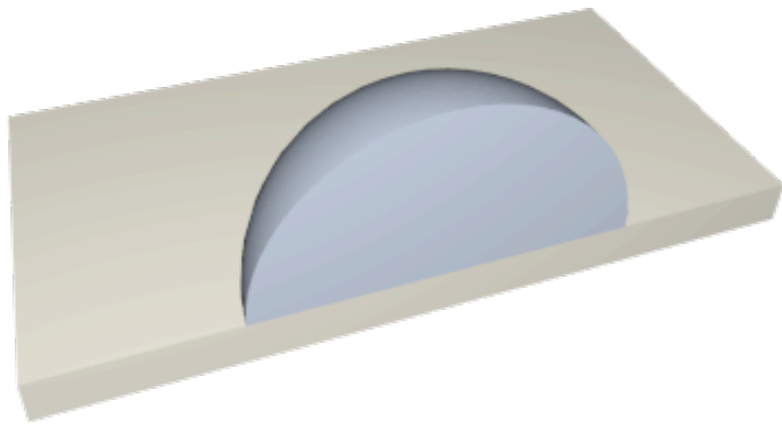

X-ray diffraction

- Scanning electron microscopy
- EDS

# Experimental (cont.)

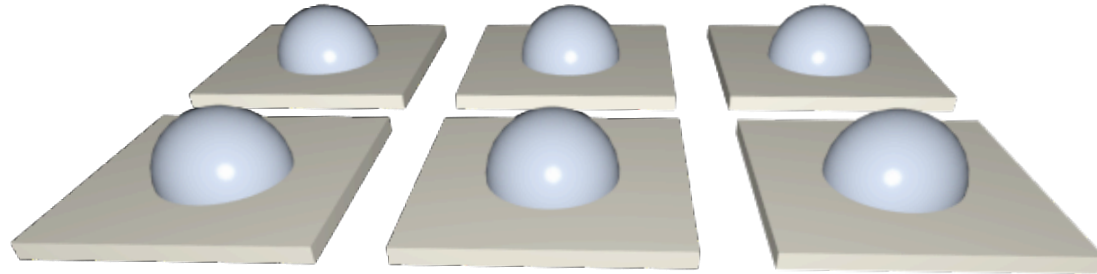

- To date we have completed the analysis of test specimens of SCN and G6 exposed for 10,000 hrs in air and ( $H_2+N_2+H_2O$ )
- Two sets of test specimens continue exposure tests (15,000+ hrs)

# Results

# Thermal Expansion and Glass Transition Temperature

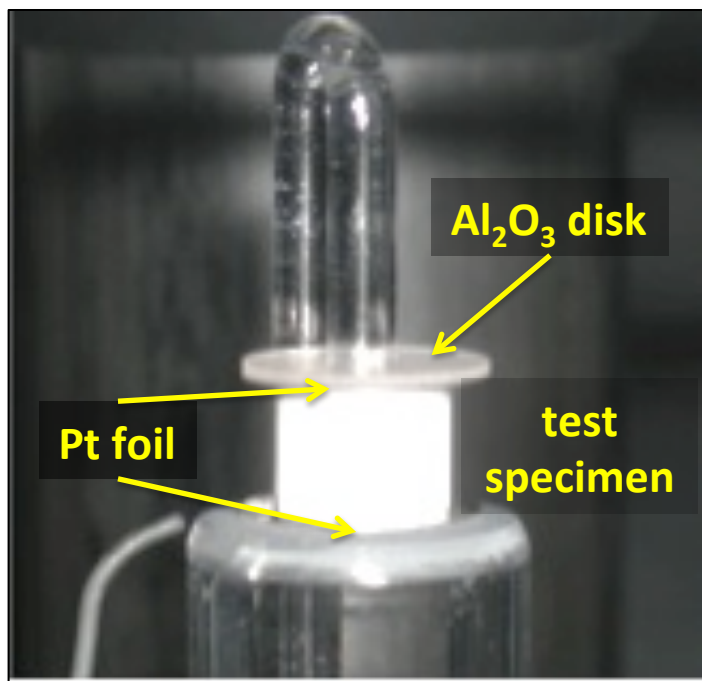

Thermomechanical Analyzer

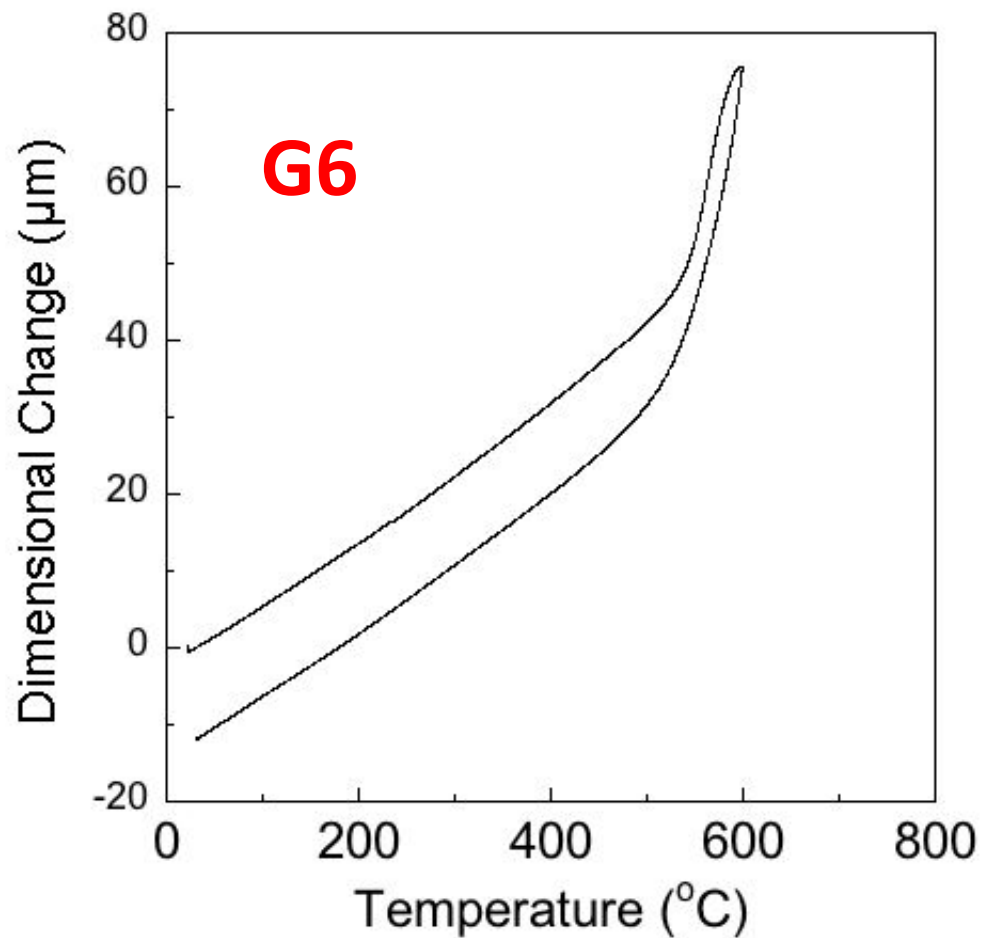

# Thermal Expansion

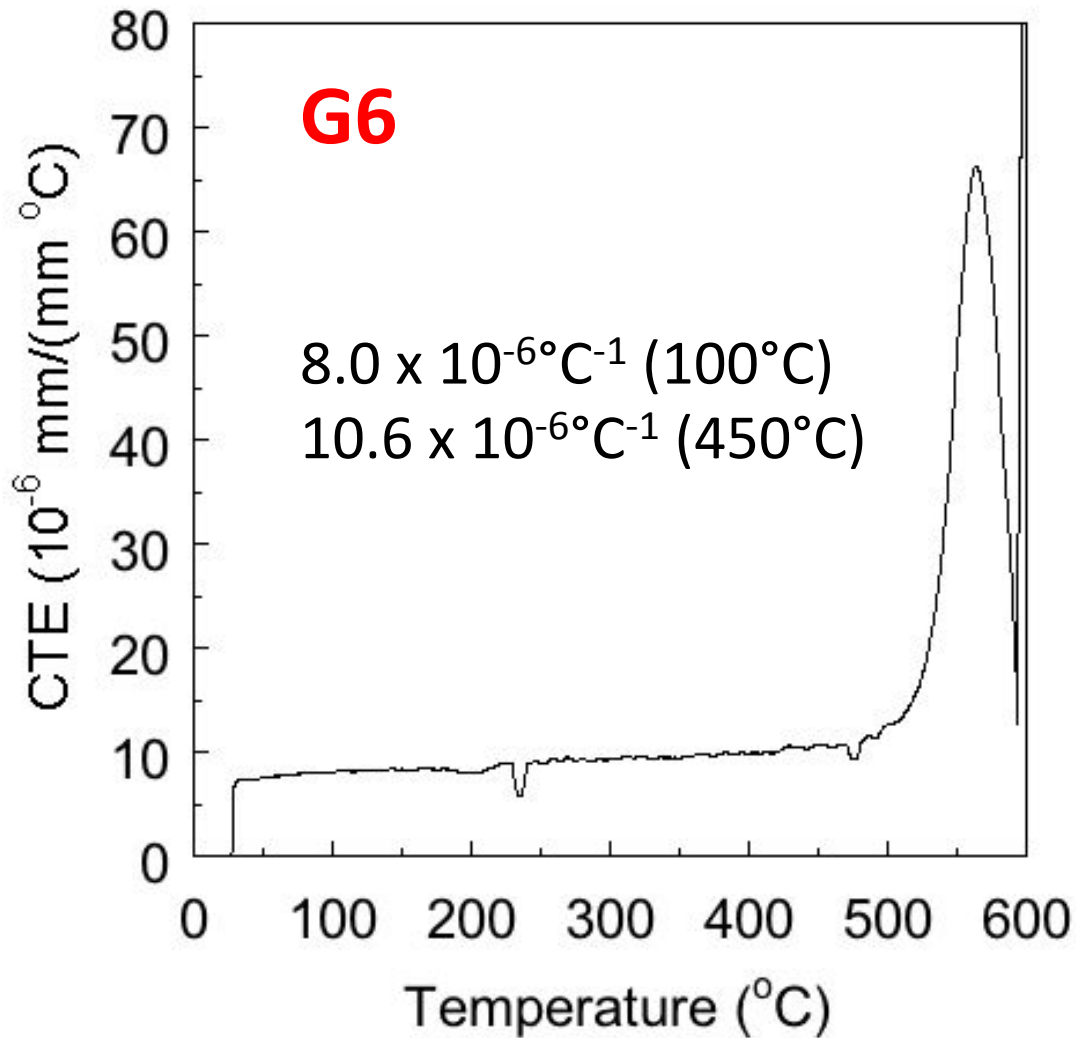

## SCN

$10.3 \times 10^{-6} \text{ } ^\circ\text{C}^{-1}$  (100°C)  
 $12.4 \times 10^{-6} \text{ } ^\circ\text{C}^{-1}$  (400°C)



# Glass Transition Temperature

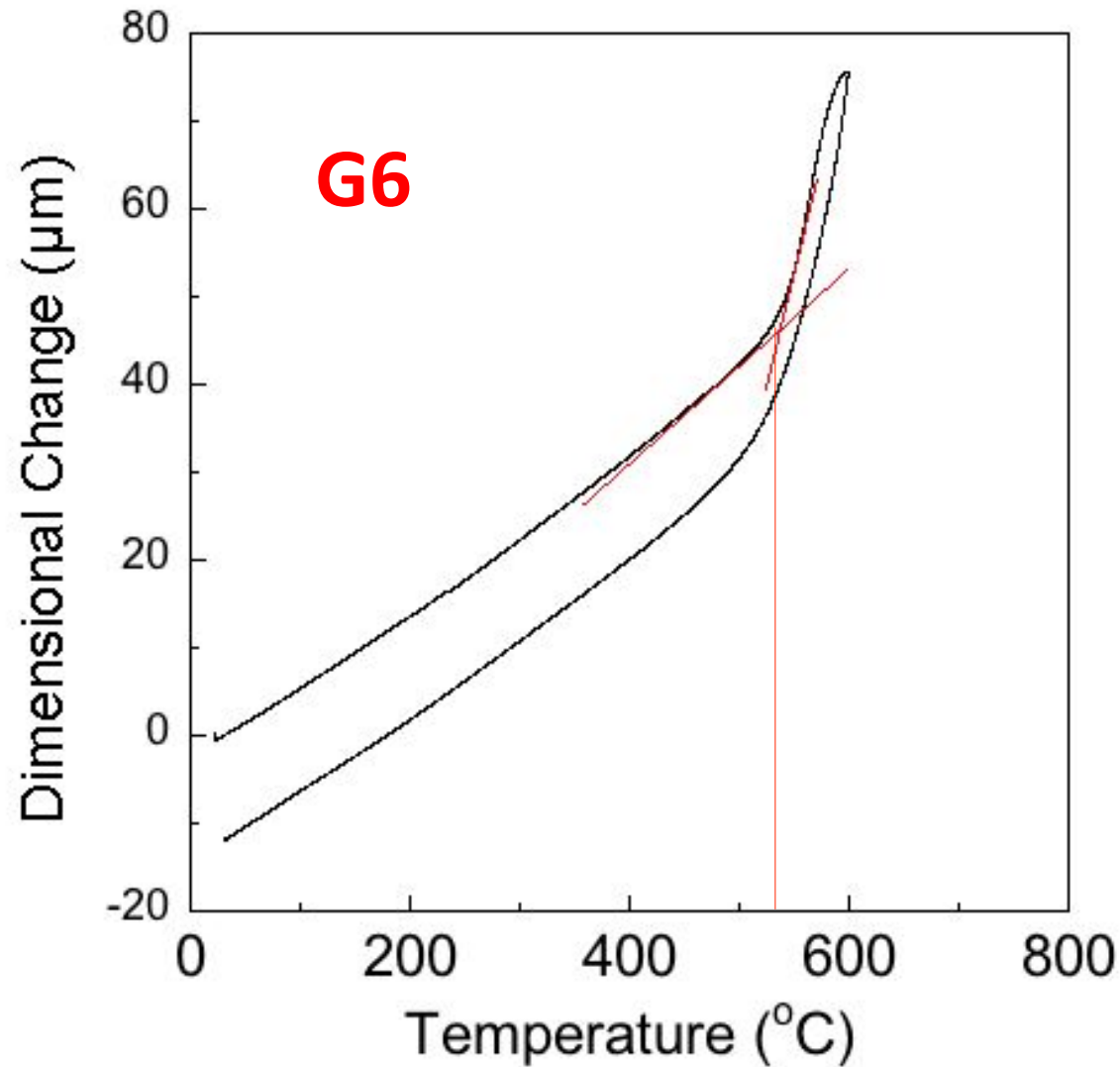

# Glass Transition Temperature

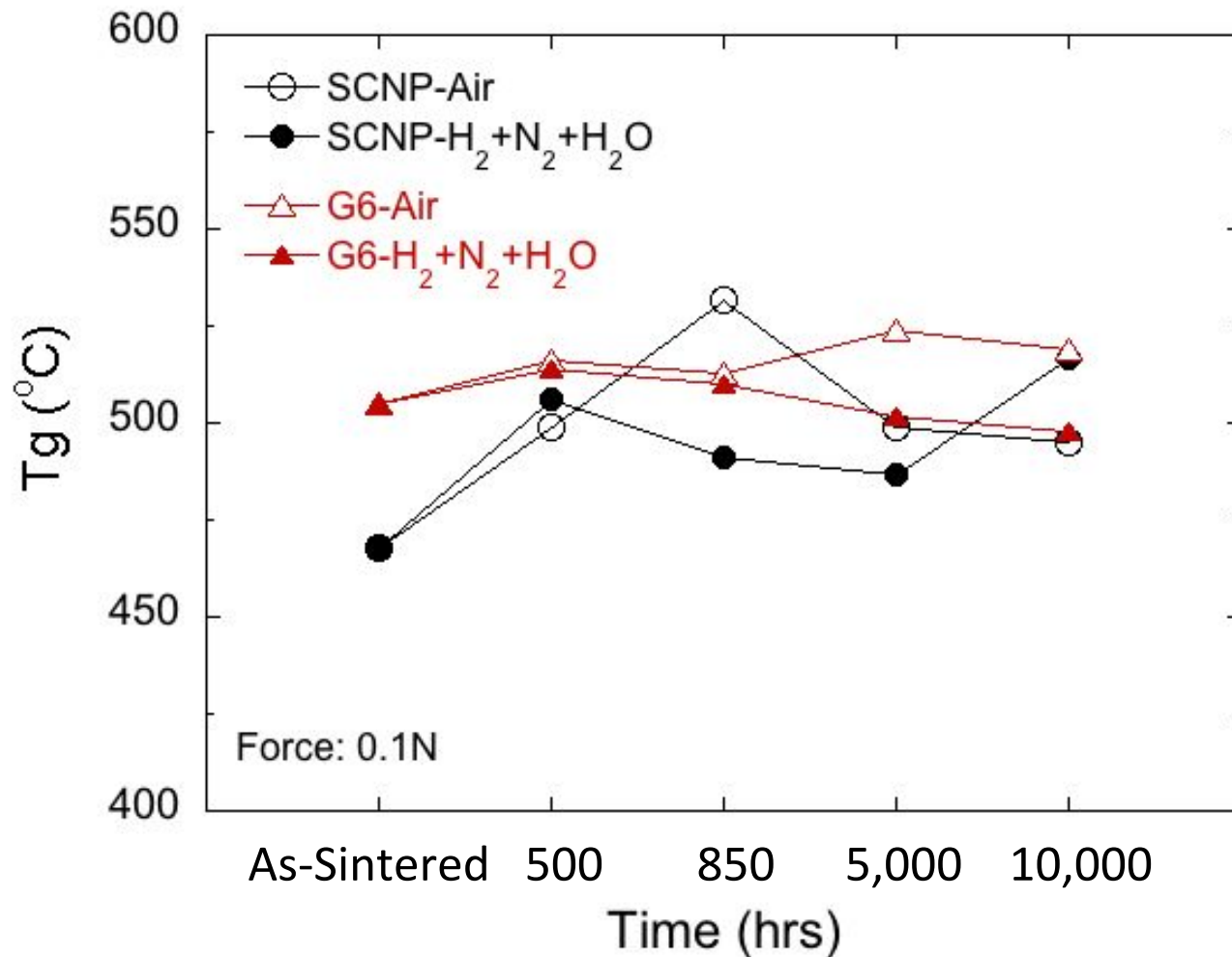

# Viscosity of G6 Glass

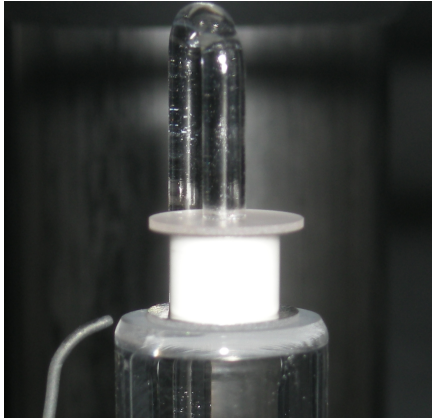

Before Viscosity Measurements



After Viscosity Measurements

## Viscosity Measurements with TMA

- Isothermal conditions (different temperatures between 600°C and 850°C) at 3 different loads (according to ASTM standard C1351)
- Constant heating rate (1°C/min) under a constant load (0.25N)

# Viscosity of G6 Glass

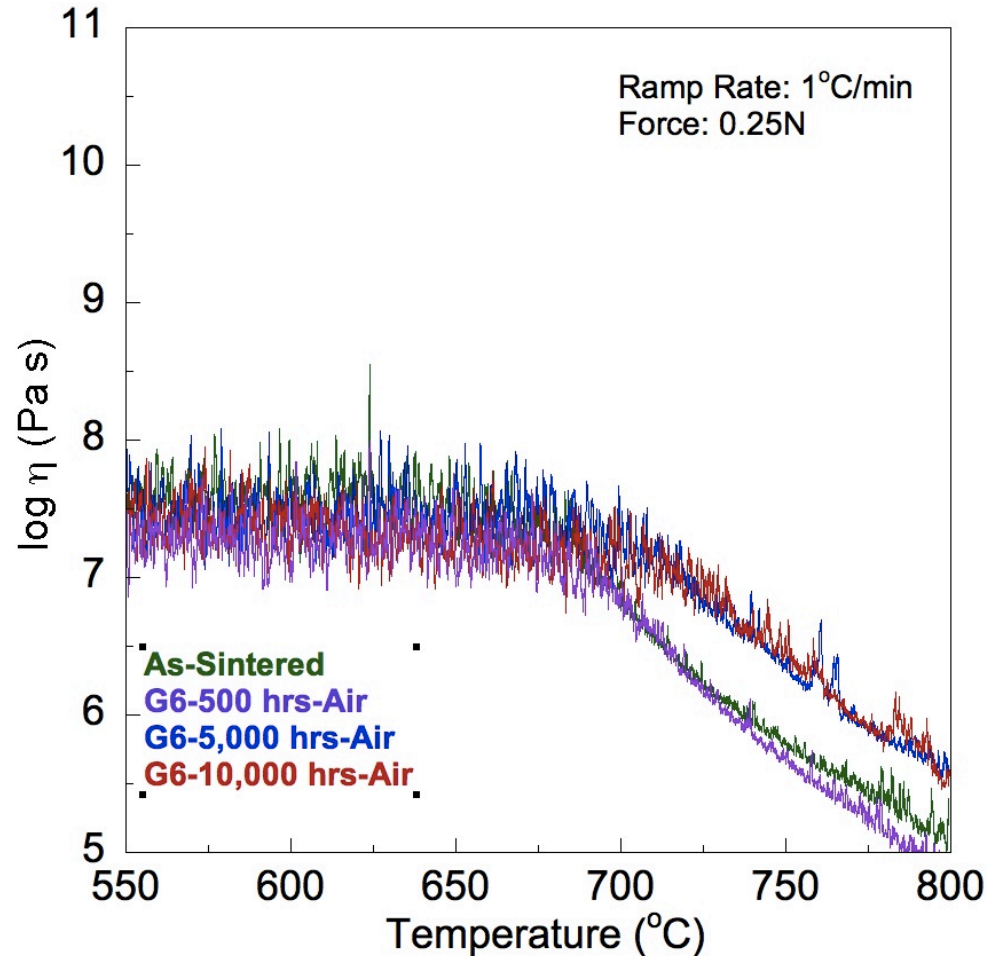

- Viscosity decreases with temperature and increases with time of exposure.
- Increase in viscosity could be explained by precipitation of crystalline phases.

# Viscosity of SCN Glass

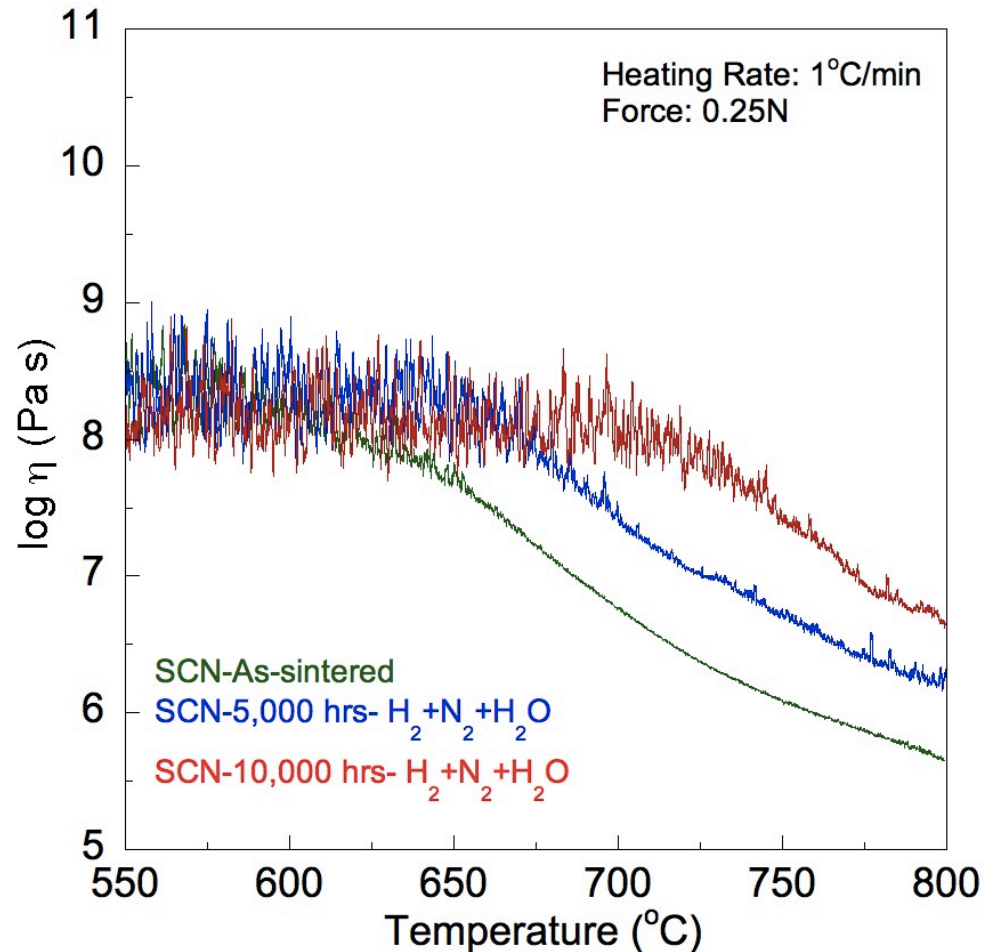

- Viscosity decreases with temperature and increases with time of exposure.
- Increase in viscosity could be explained by precipitation of crystalline phases.

# Microstructural Evolution of multicomponent silicate glasses

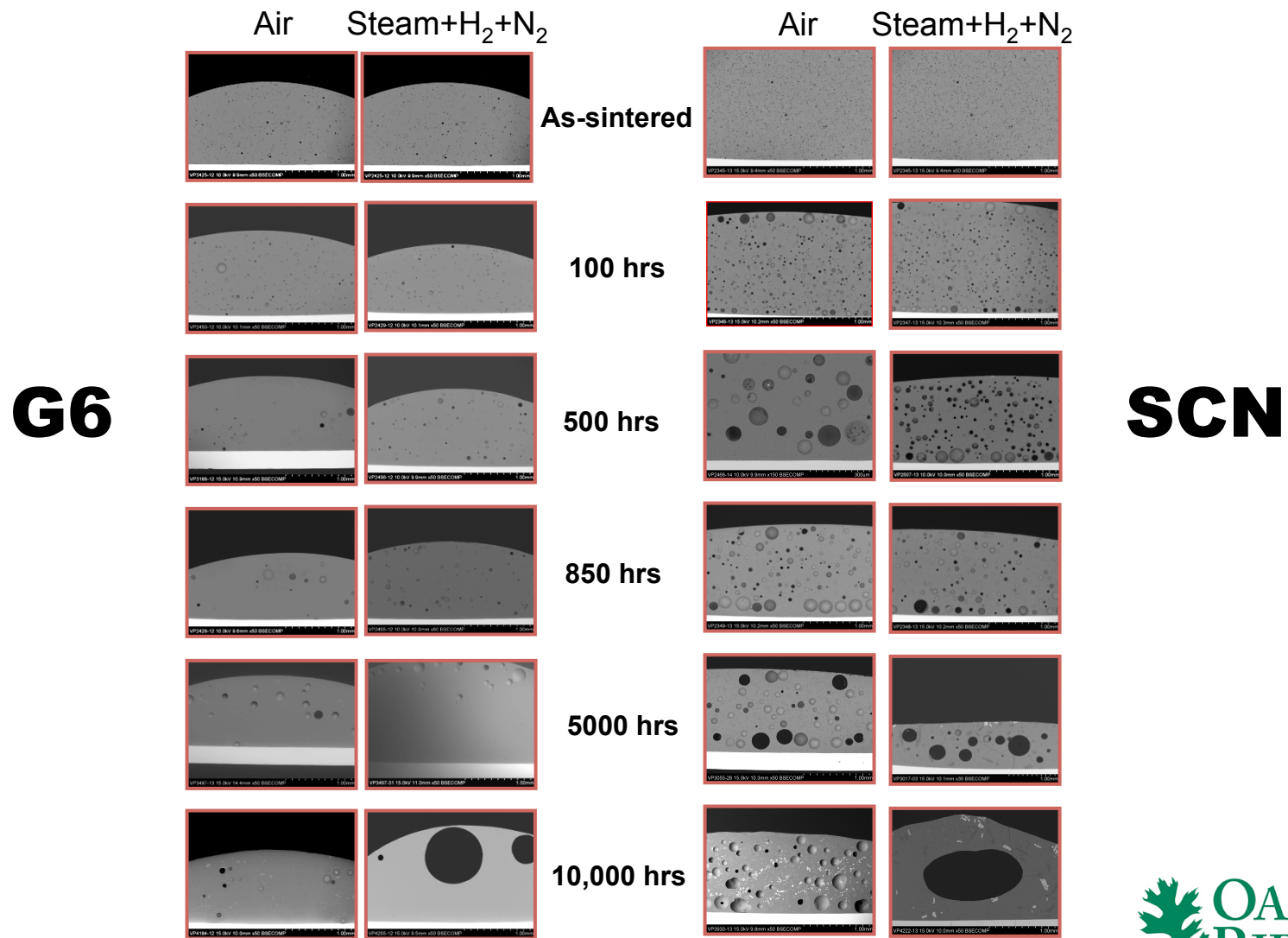

Lara-Curzio et al. 2012 SECA Workshop

# G6-YSZ-54

After 10,000 Hours in Steam+H<sub>2</sub>+N<sub>2</sub>

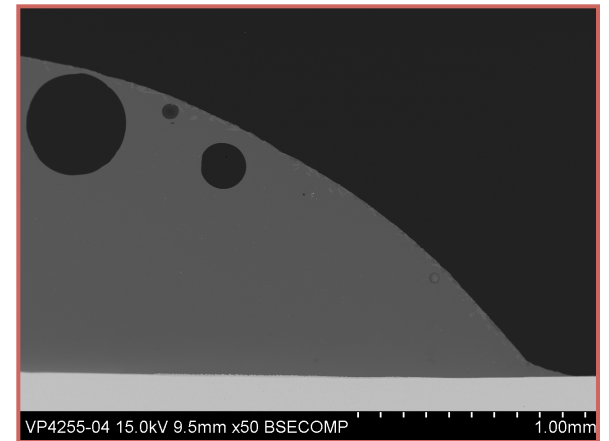
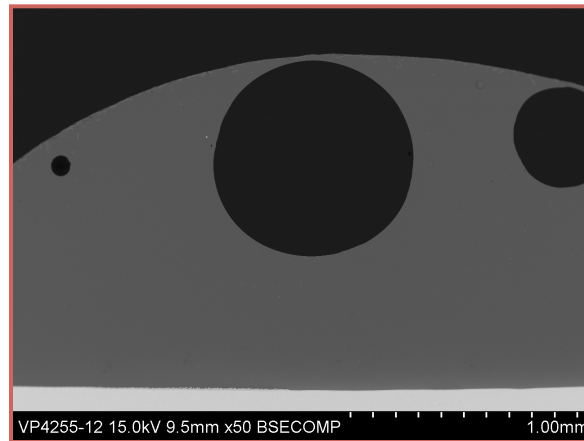
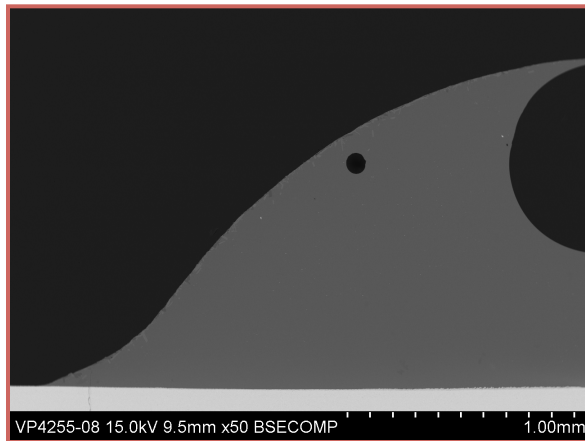
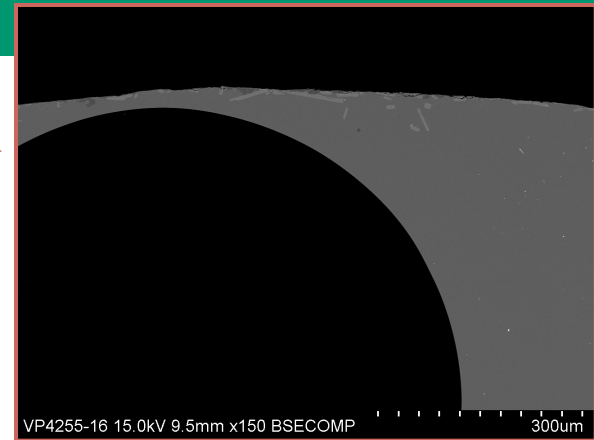
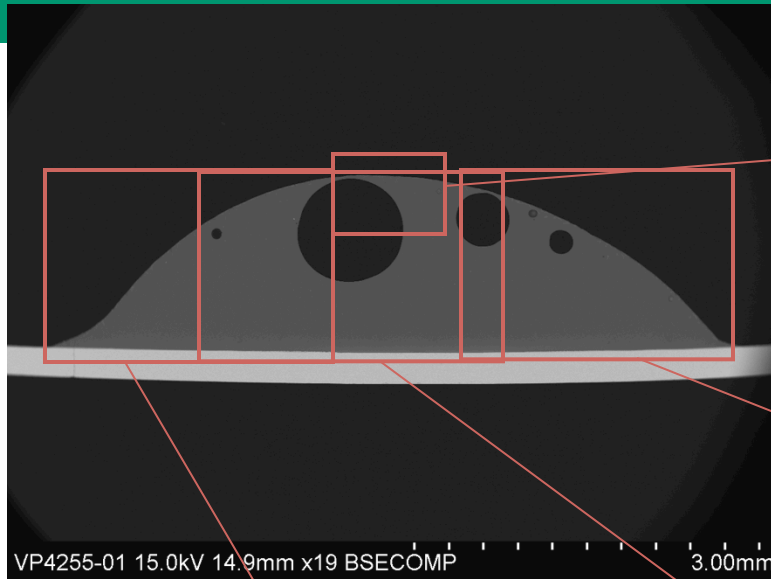

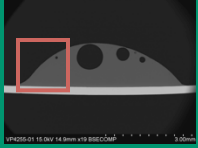

# G6-YSZ-54

After 10,000 Hours in Steam+H<sub>2</sub>+N<sub>2</sub>

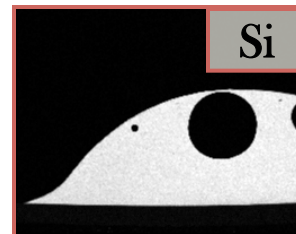
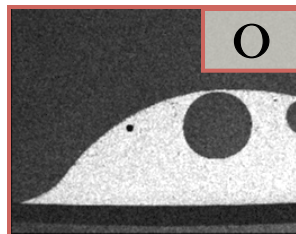
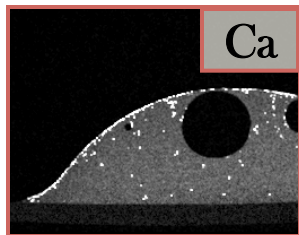
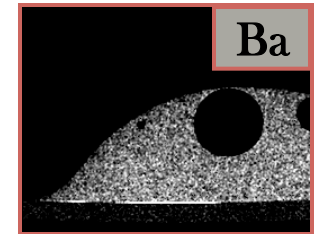
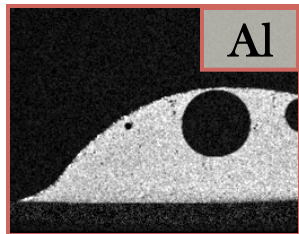
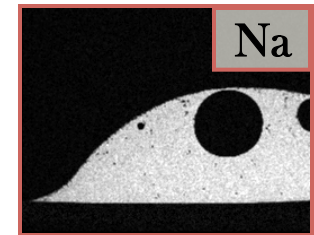
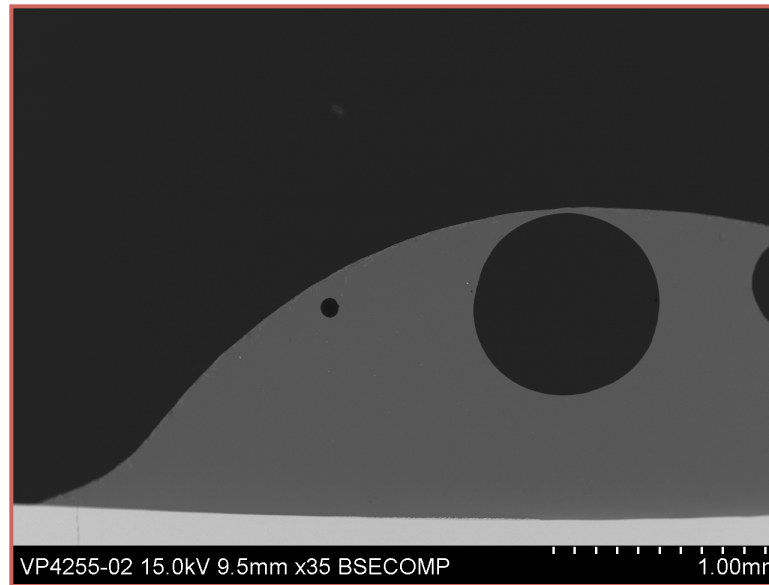
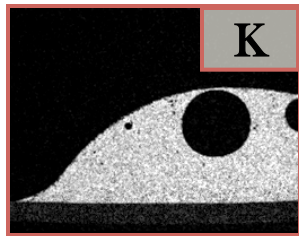
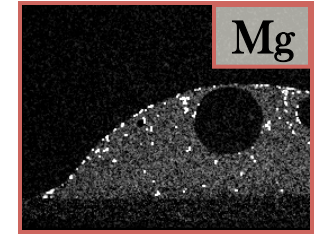
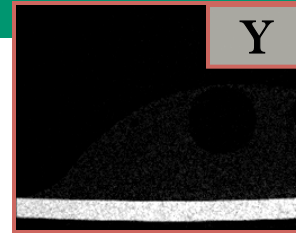
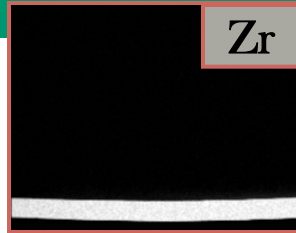





# G6-YSZ-54

After 10,000 Hours in Steam+H<sub>2</sub>+N<sub>2</sub>

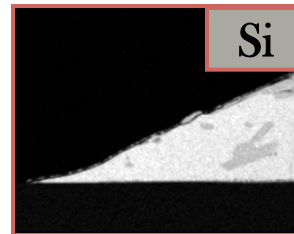
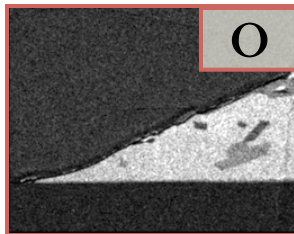
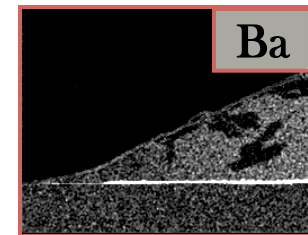
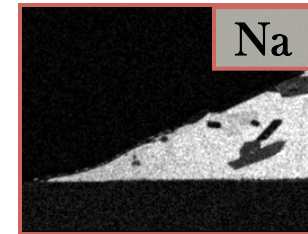
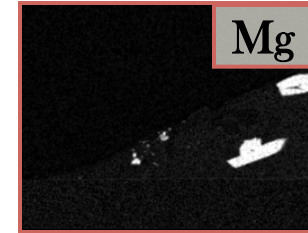
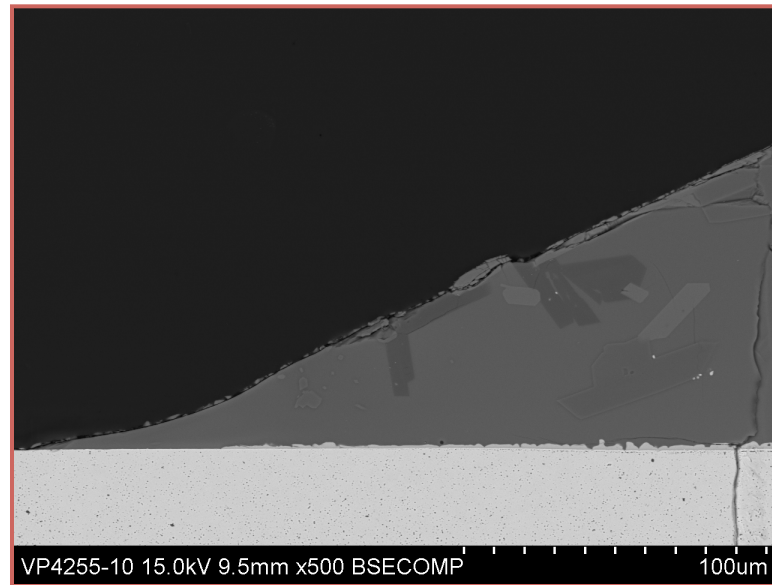
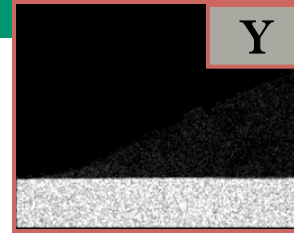
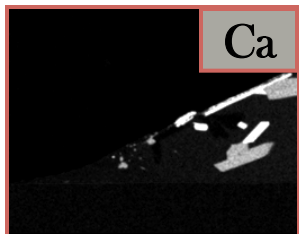
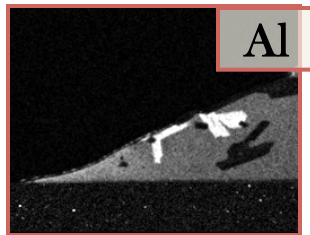
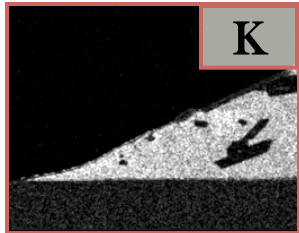

# G6-YSZ-51

After 10,000 Hours in Air

# G6-YSZ-51

After 10,000 Hours in Air

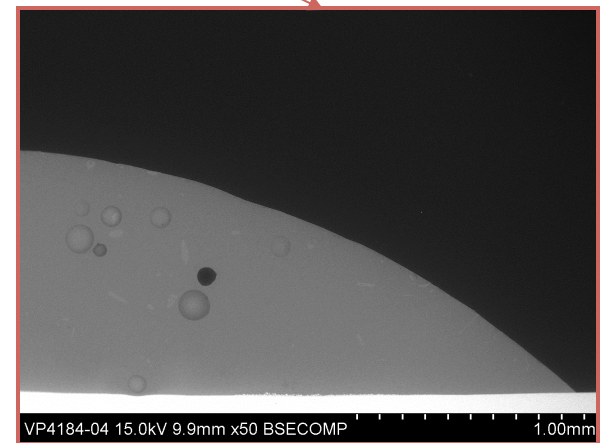
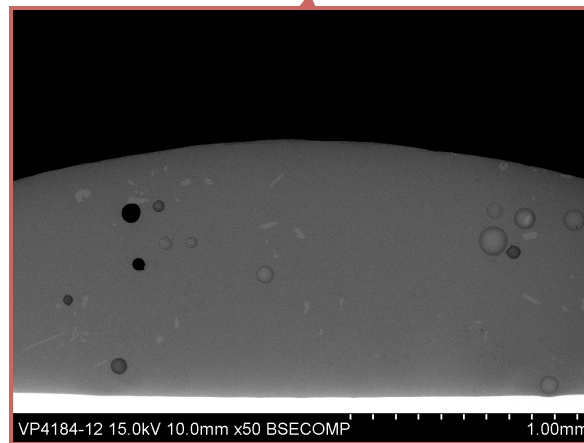
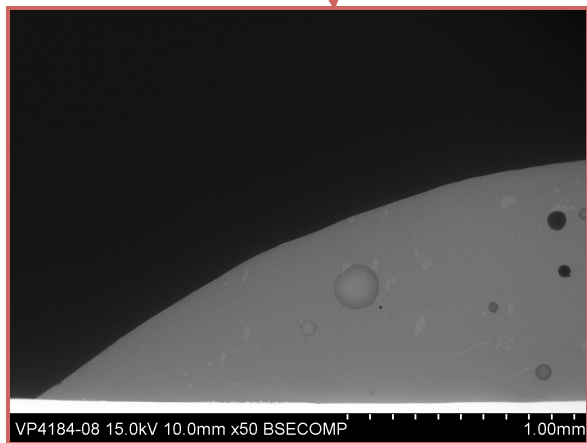
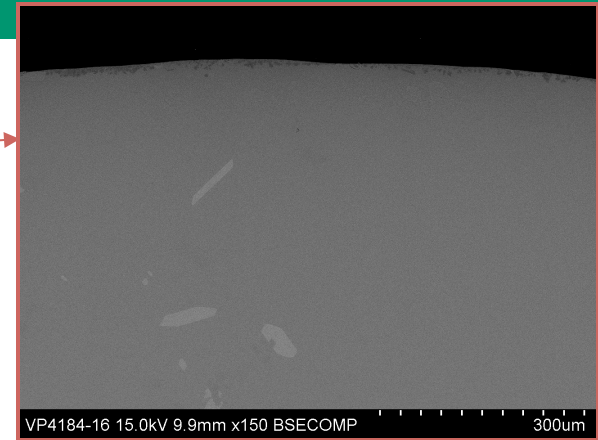
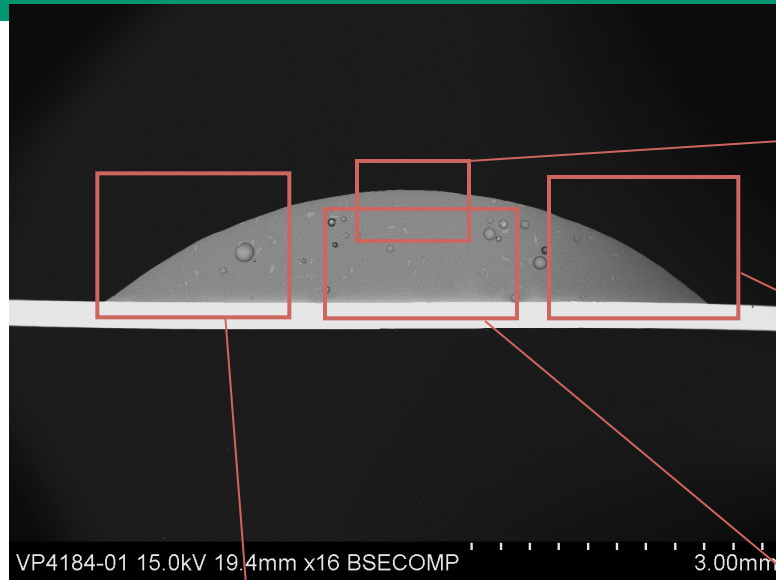

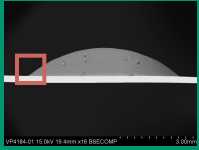

# G6-YSZ-51

After 10,000 Hours in Air

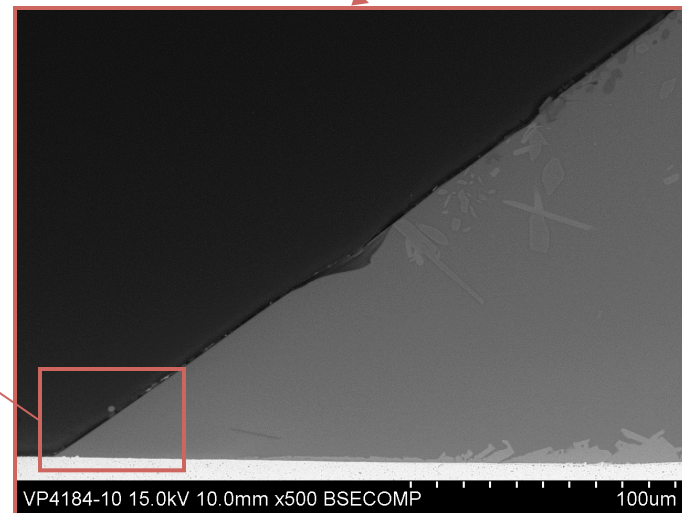
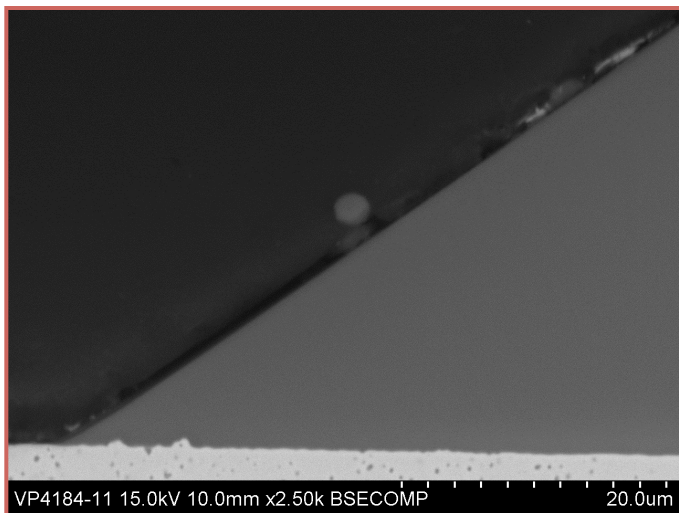
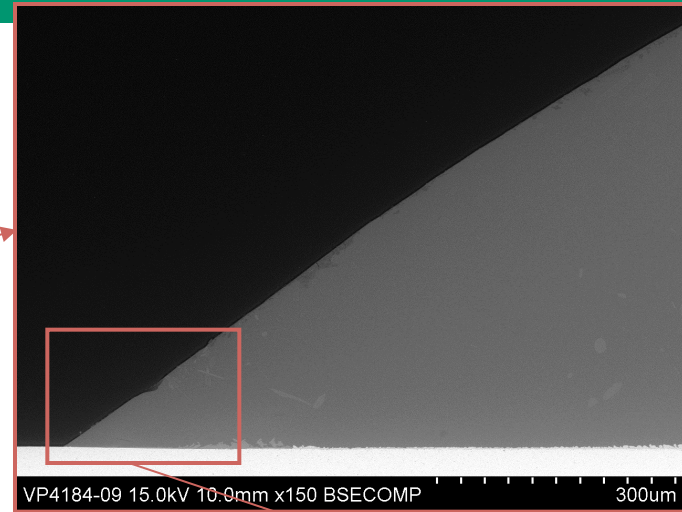
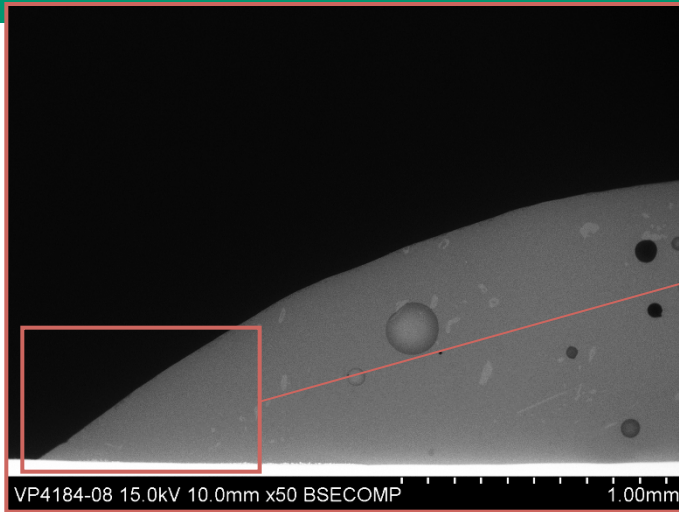

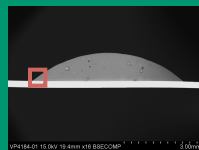

# G6-YSZ-51

After 10,000 Hours in Air

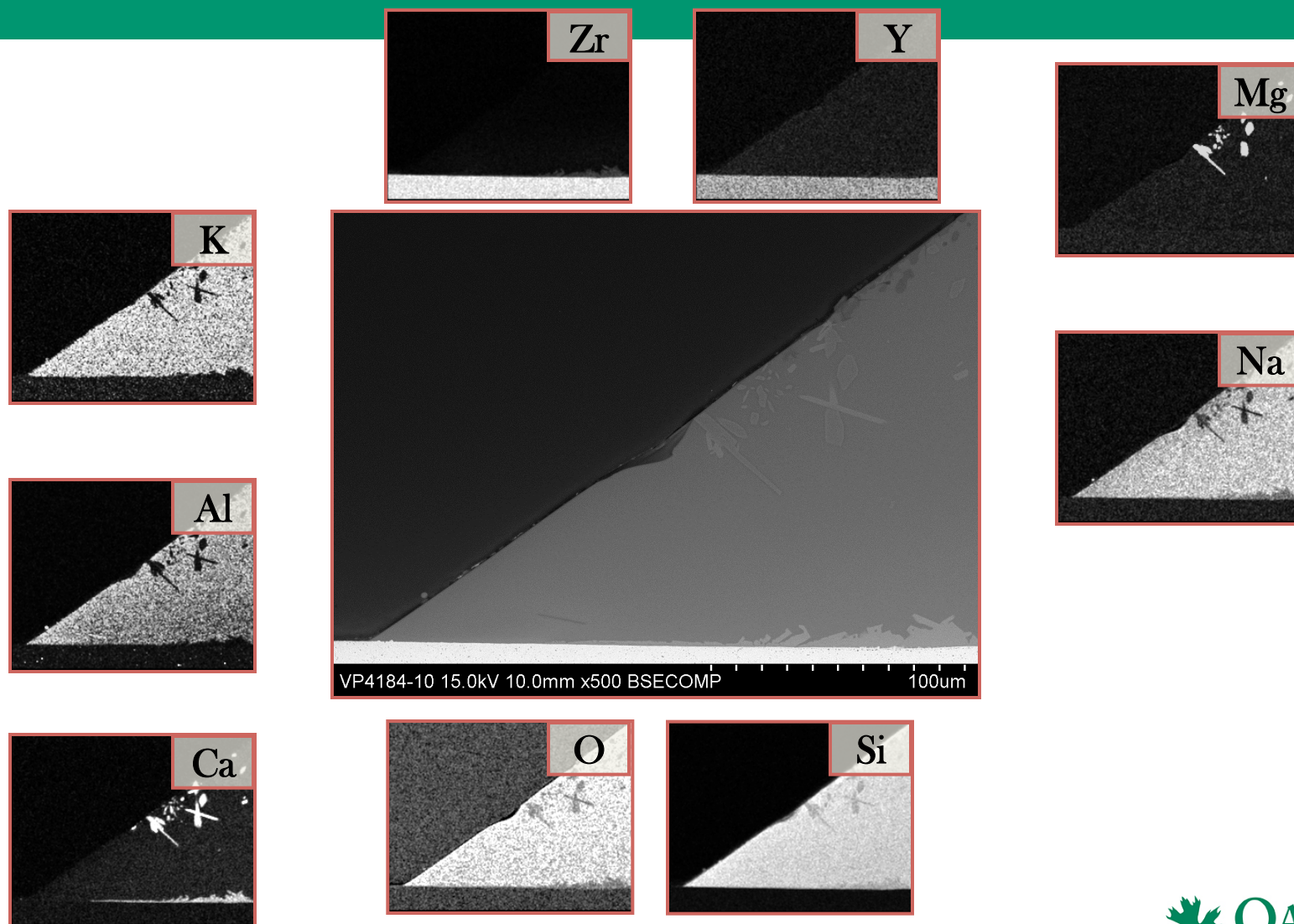

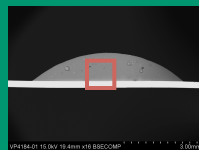

# G6-YSZ-51

After 10,000 Hours in Air

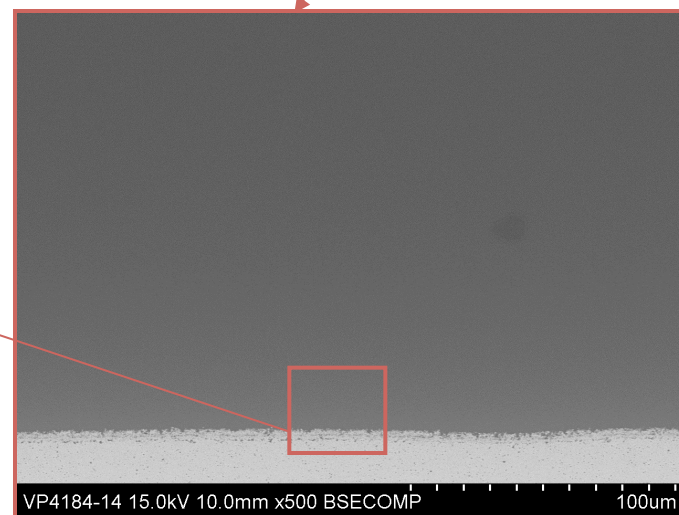
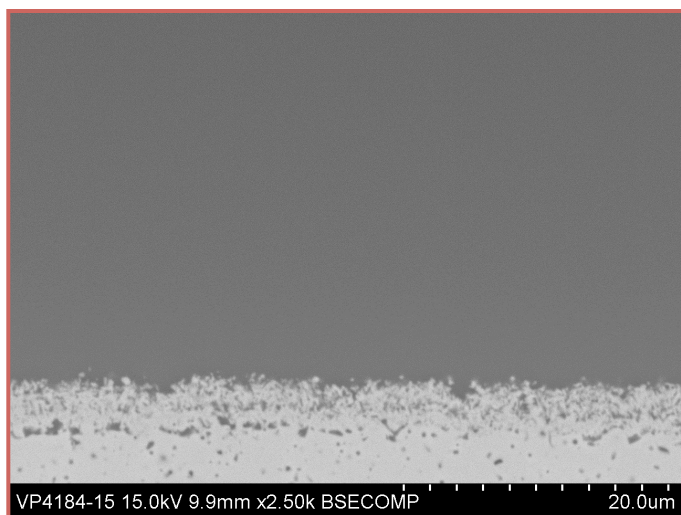
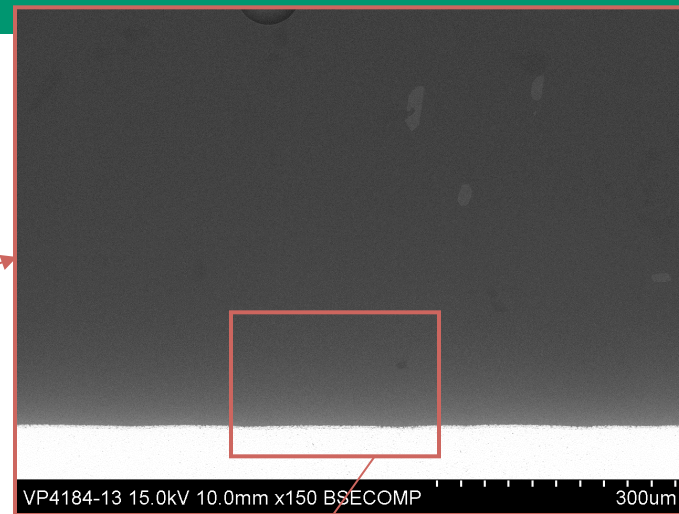
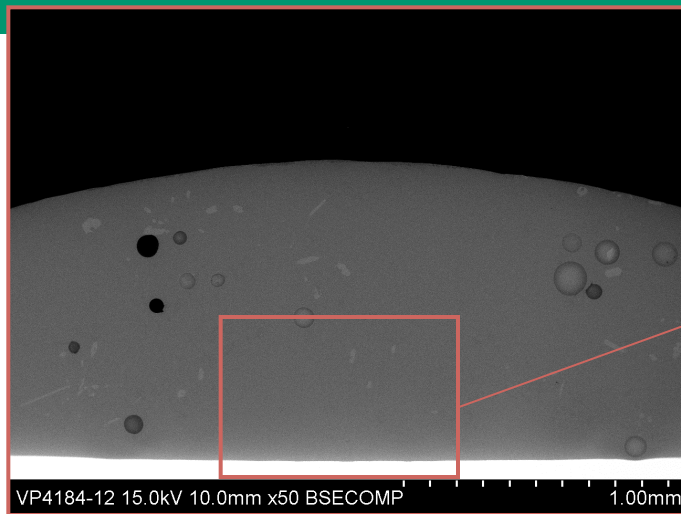

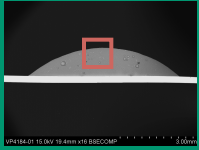

# G6-YSZ-51

After 10,000 Hours in Air

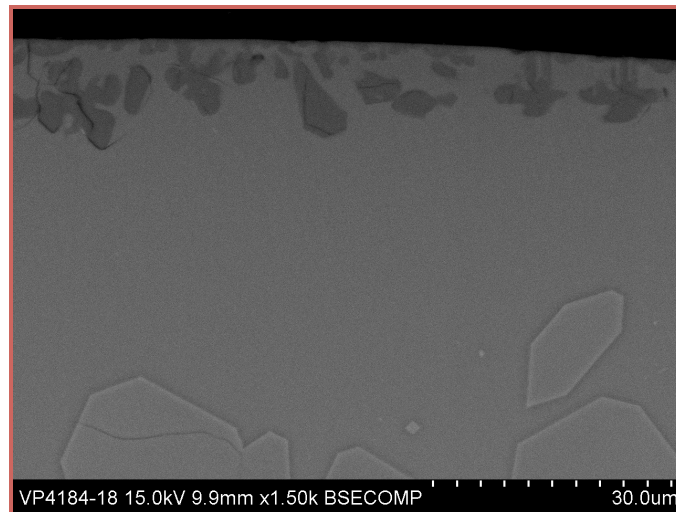
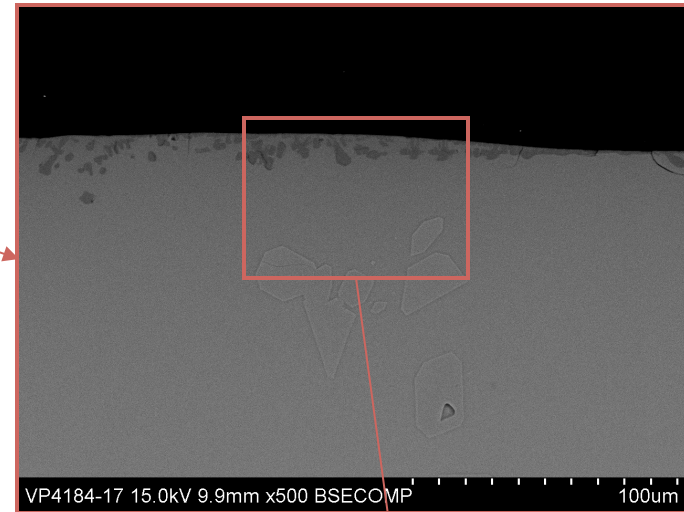
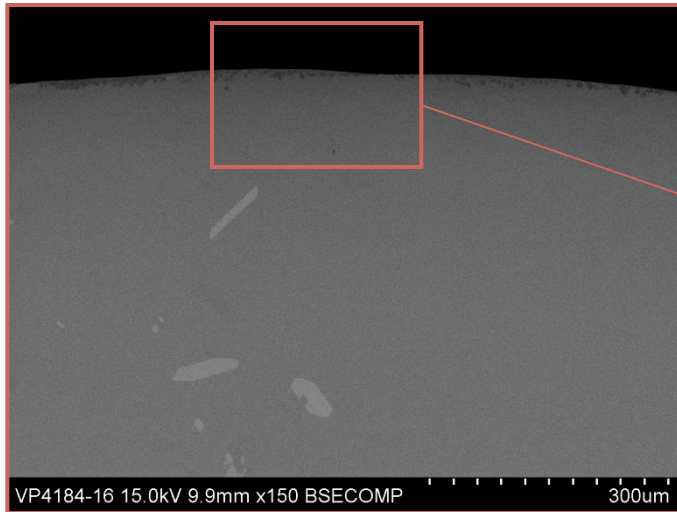

Lara-Curzio et al. 2012 SECA Workshop

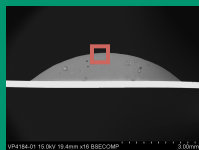

# G6-YSZ-51

After 10,000 Hours in Air

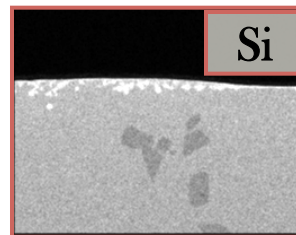
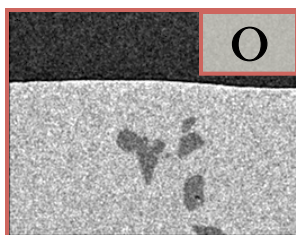
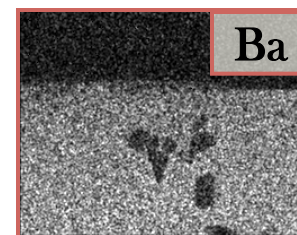
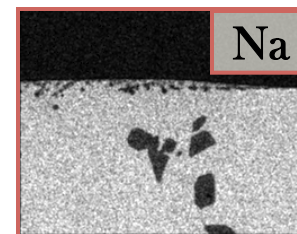
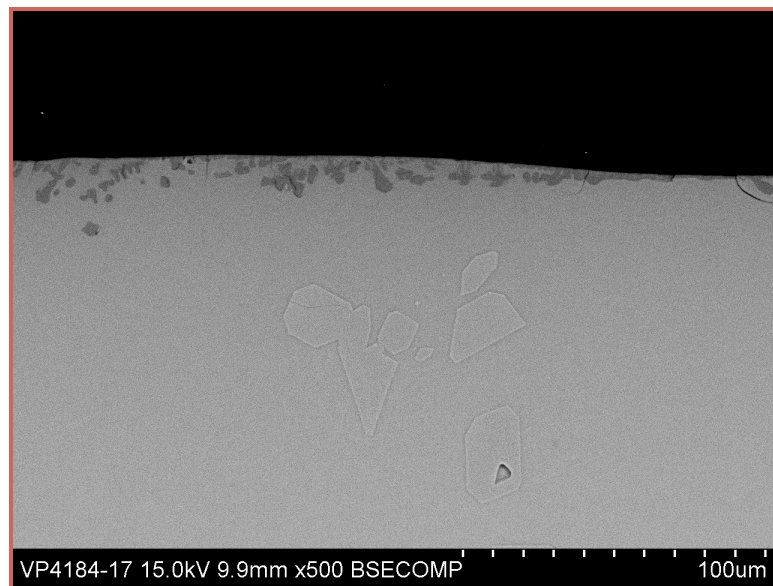
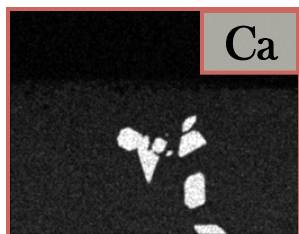
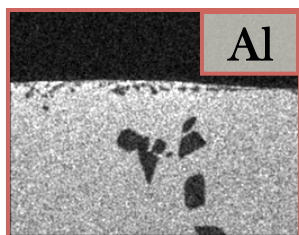
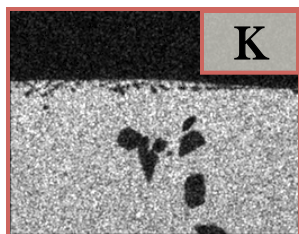



# G6-Al<sub>2</sub>O<sub>3</sub> and G6-YSZ (air): powder XRD

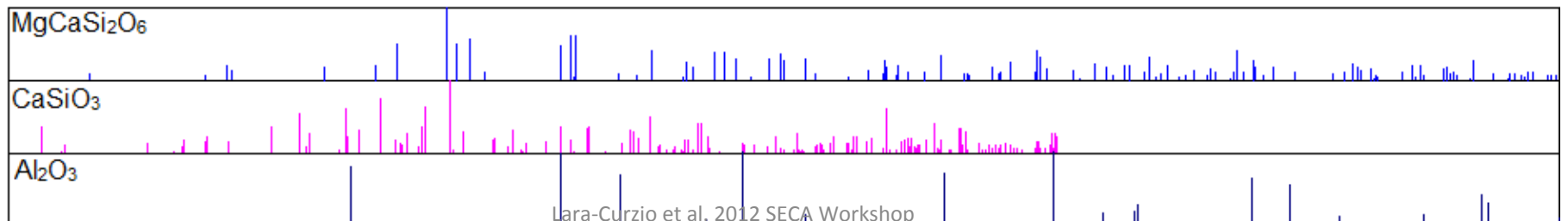
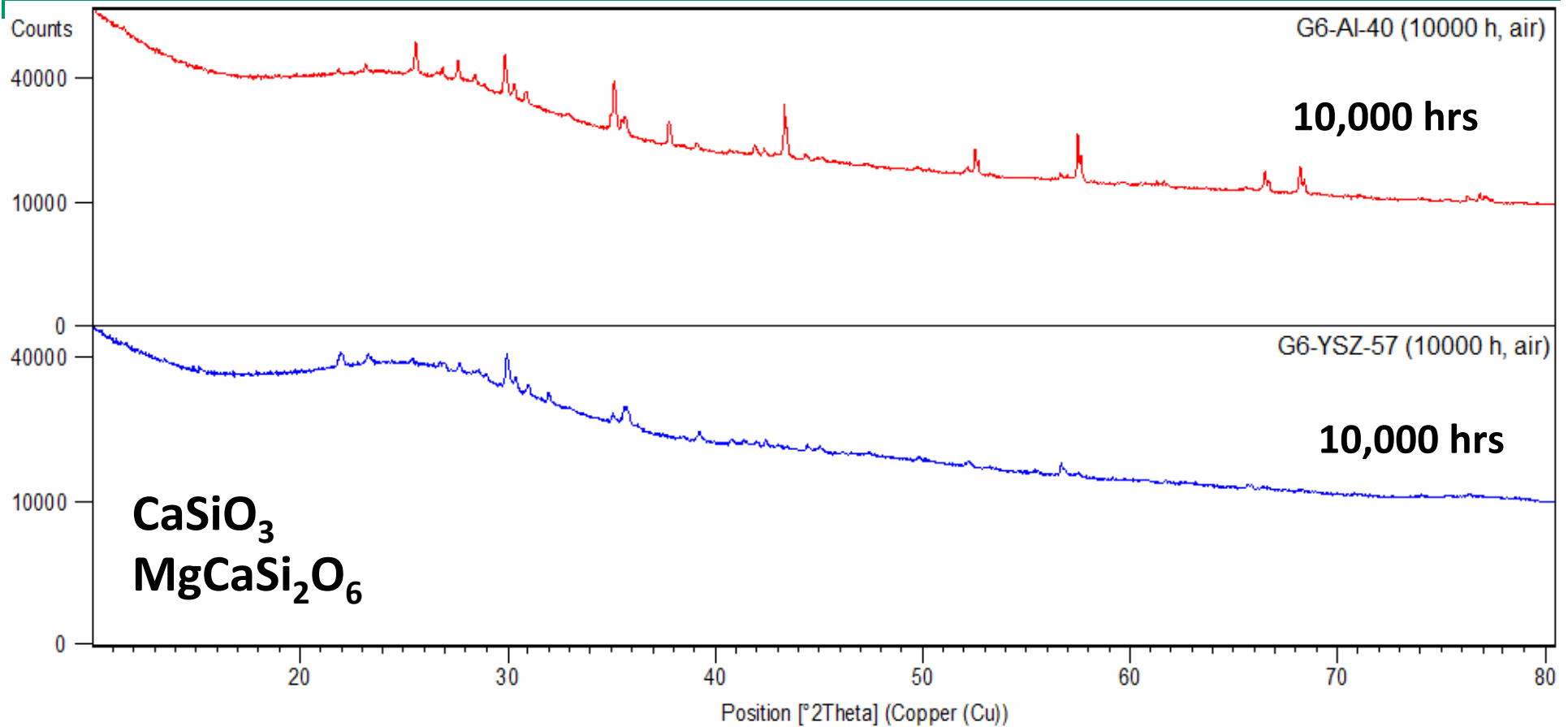

# Rates of Crystallization (SCN Glass)

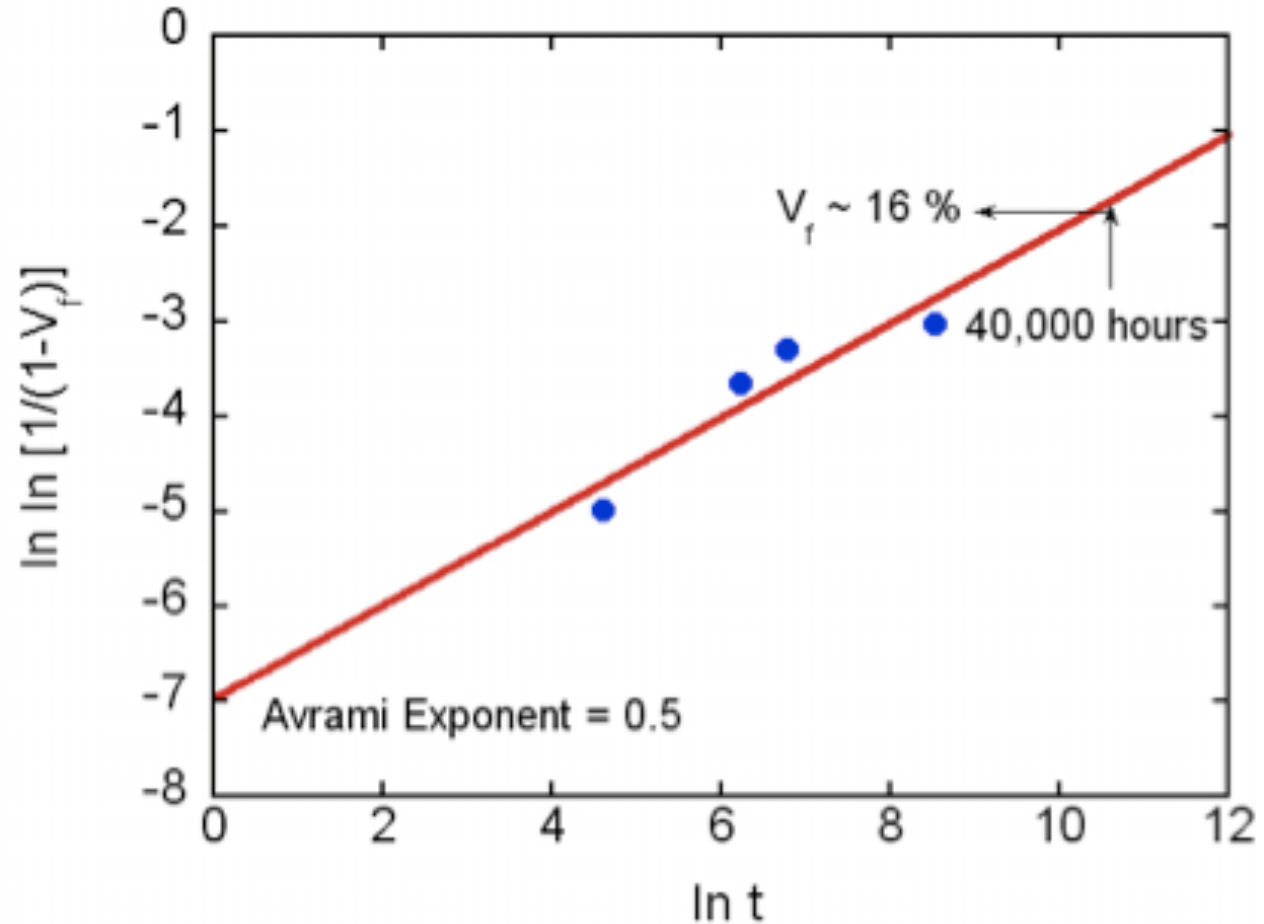
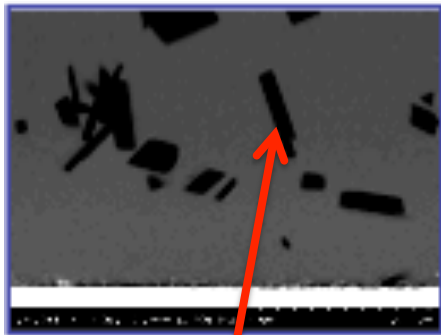

# Chemical Analysis

- Performed a study to assess the precision of different chemical analysis methods (**Al, B, Ba, Ca, Fe, K, Li, Mg, Na, Si, Ti, Zn, Zr**)
  - Neutron Activation Analysis
  - Inductively Coupled Plasma Atomic Emission (ICPAES)
  - Inductively Coupled Plasma Mass Spectroscopy (ICPMS)
  - Atom Probe Tomography
- Sample Preparation Requirements

# Chemical Analysis using Atom Probe Tomography

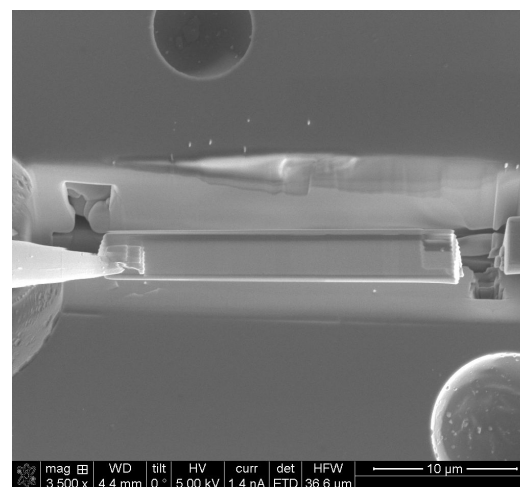
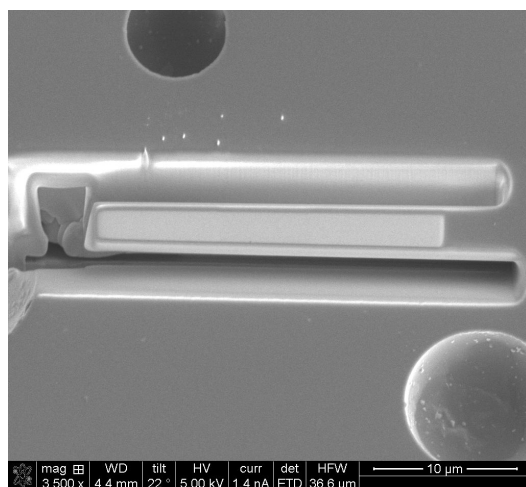
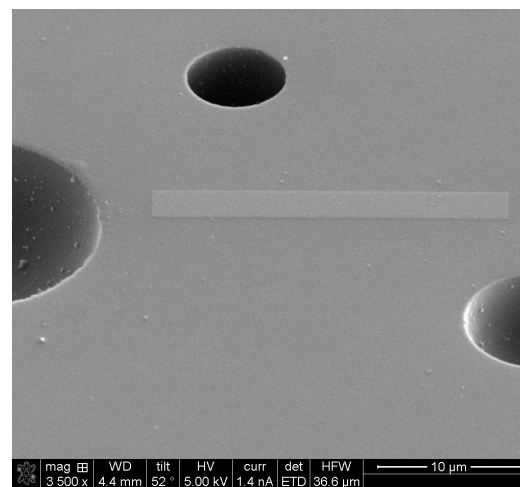
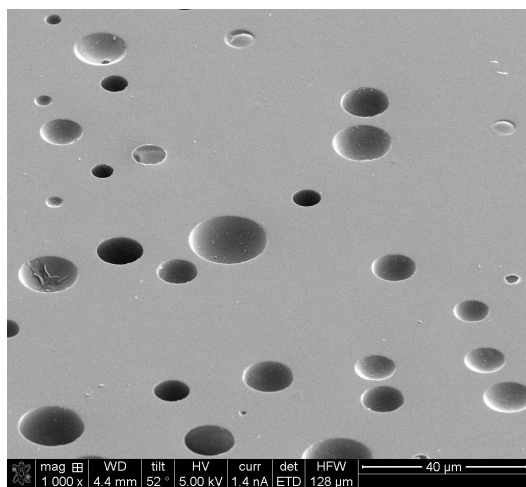

SCN glass

Lara-Curzio et al. 2012 SECA Workshop

# Chemical Analysis using Atom Probe Tomography

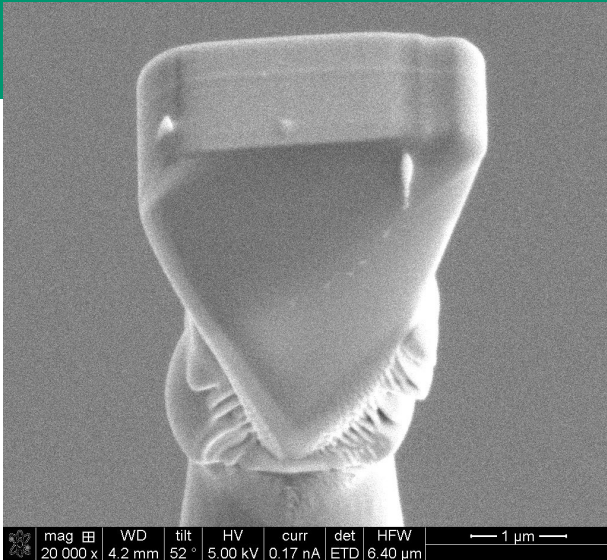

Attach to micropost

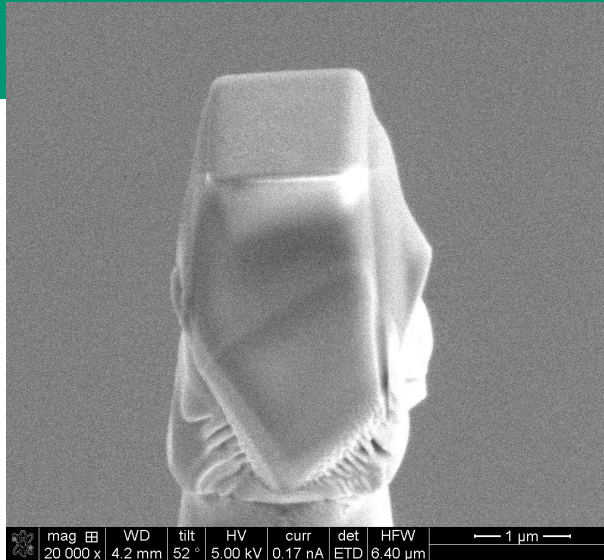

Trim square

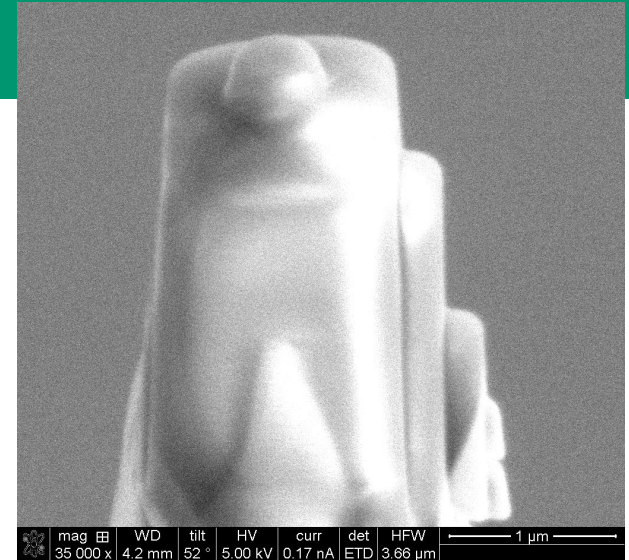

Sharpen w. annular milling pattern

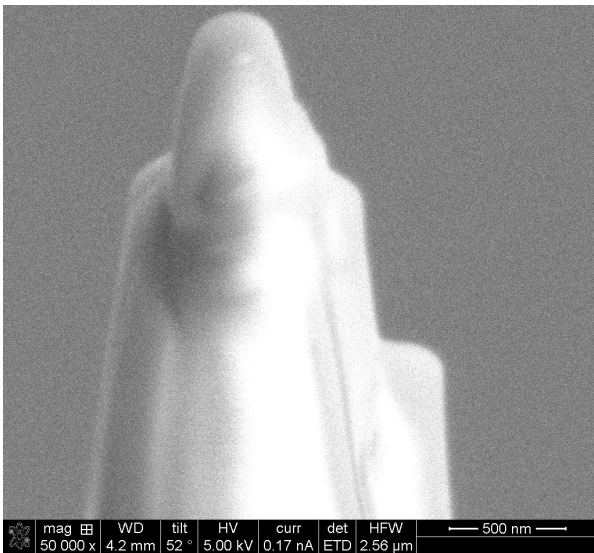

30kV 280 pA ion beam annular pattern

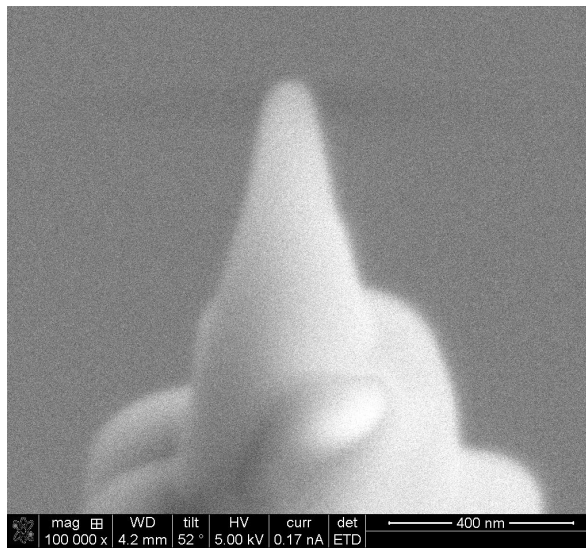

30kV 28pA ion beam annular pattern

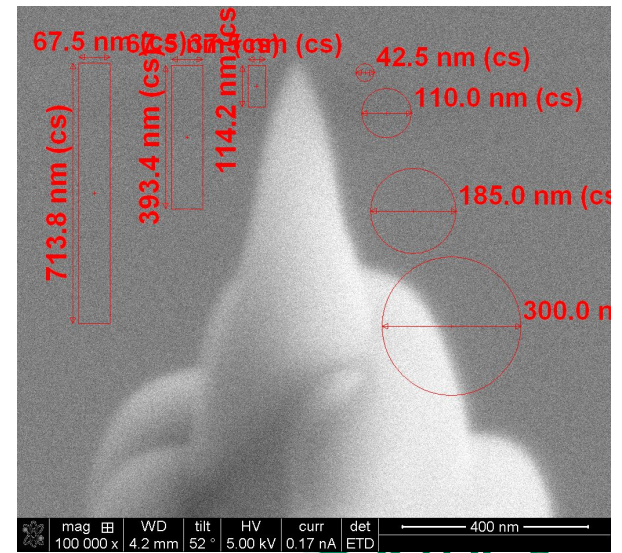

Touch up with 5kV 16pA ion beam

# 3D Atom Probe Tomography Reconstruction

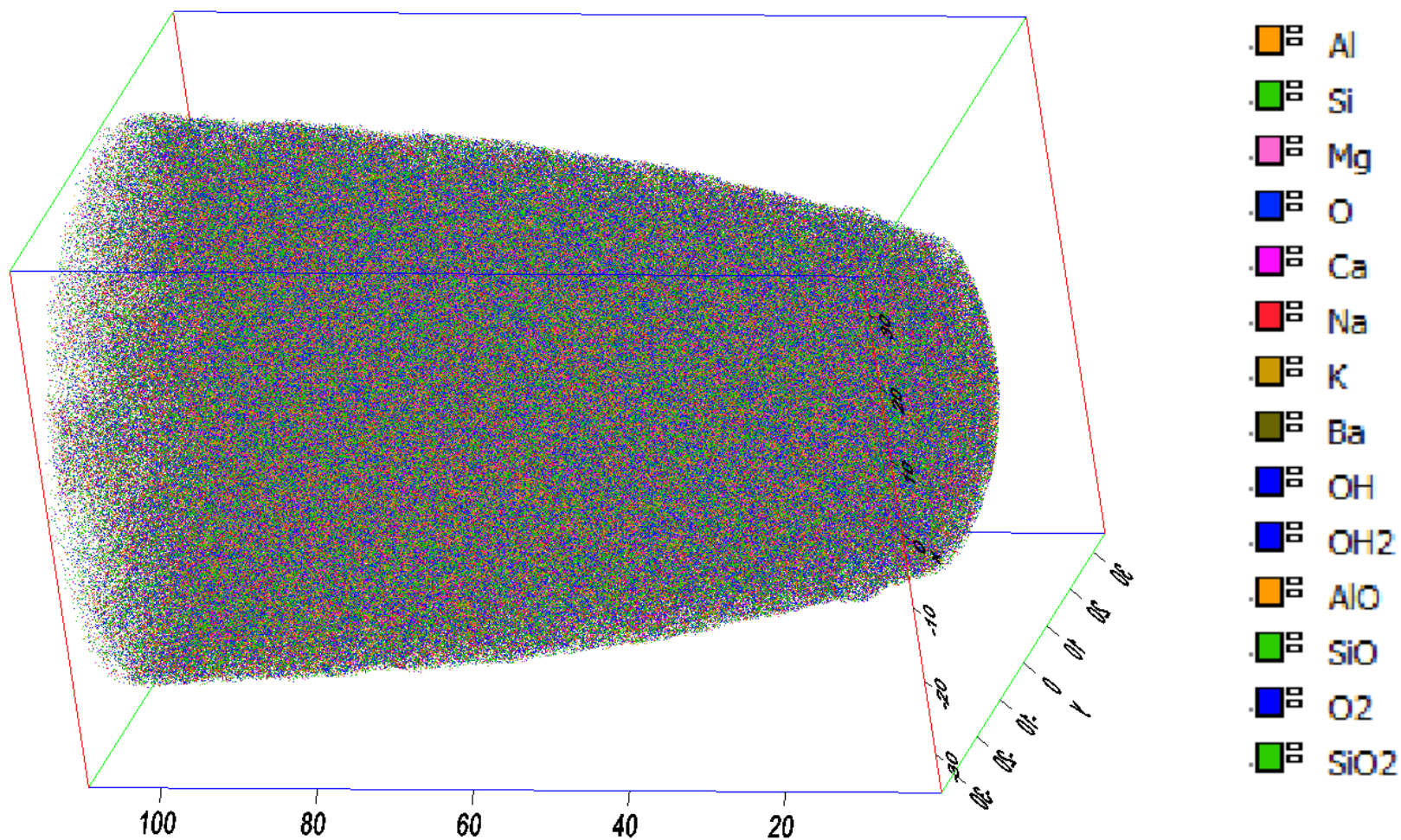

3,997,448 ranged atoms in  $70 \times 70 \times 109 \text{ nm}^3$   
Reconstructed Volume

# LEAP mass spectrum

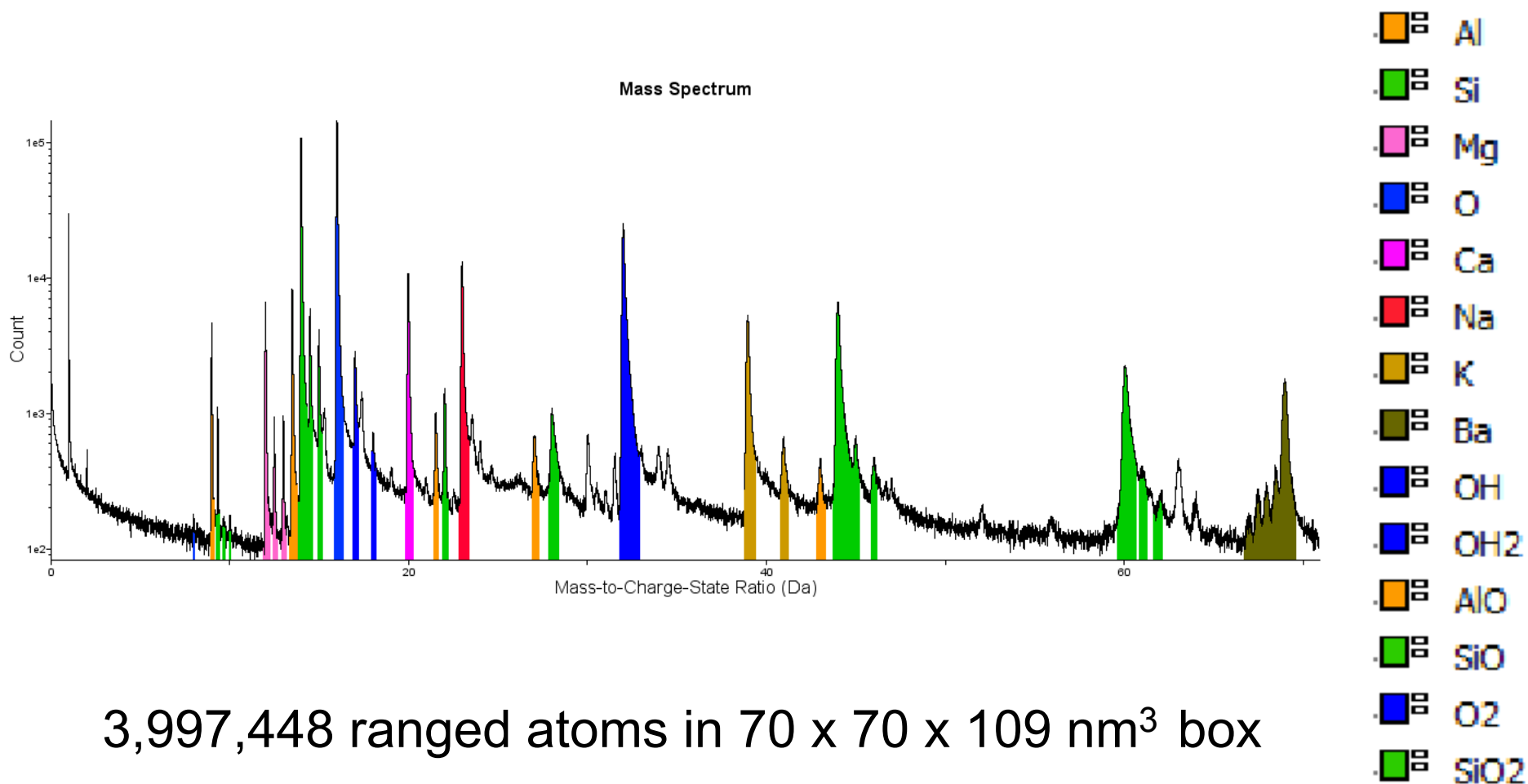

3,997,448 ranged atoms in 70 x 70 x 109 nm<sup>3</sup> box

# Composition SCN Glass

## As sintered

Element	at %
O	57.13
Si	25.64
K	2.85
Ba*	2.00
Na	3.84
Ca	2.32
Al	2.64
Mg	1.21
Ti	0.06
B	0.04
Zn	0.01

## After 10,000 in air

Element	at %
O	59.26
Si	28.54
K	1.60
Ba*	1.76
Na	1.66
Ca	1.66
Al	2.34
Mg	1.36
Ti	0.06
B	0.04
Zn	0.01



# Challenges for sealing SOFCs using crystallization-resistant glasses

## Control of viscosity and seal compliance

- **Scaling up to cells with large active surface area**
  - **Flatness**
  - **Parallelism**
- **Temperature gradients**

# Temperature Gradients in SOFCs

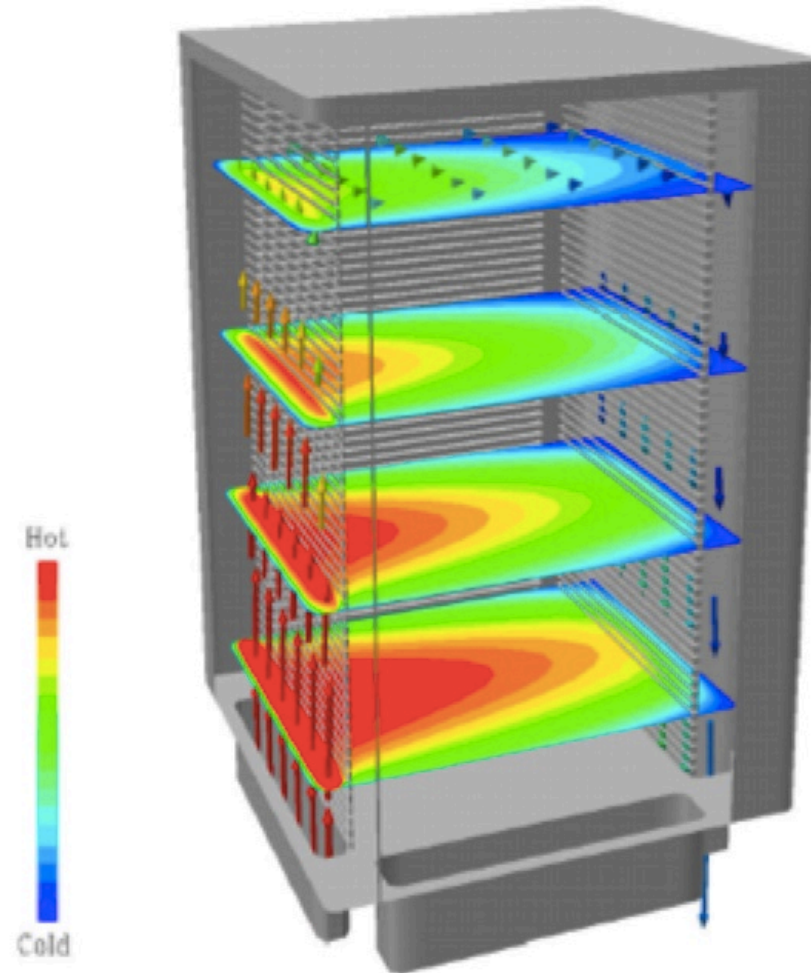

PNNL (2004)

# Viscosity of G6 Glass

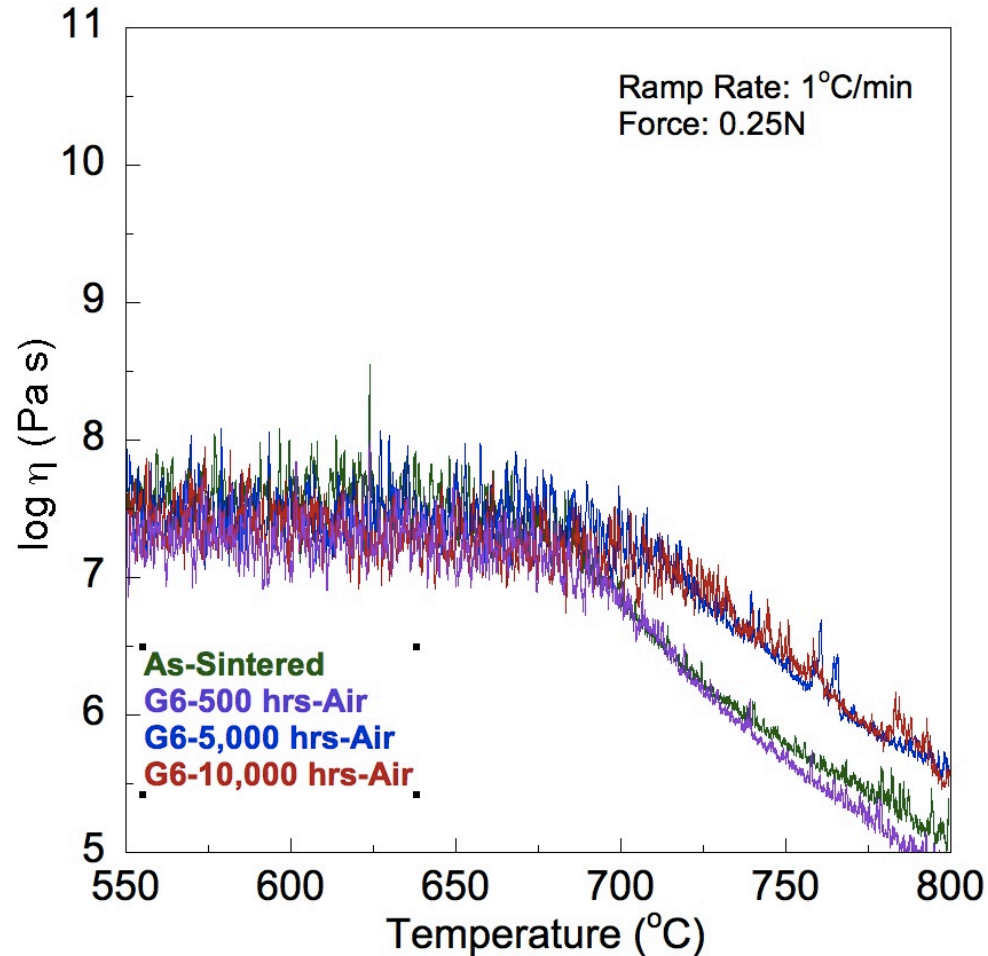

- Viscosity decreases with temperature and increases with time of exposure.
- Increase in viscosity could be explained by precipitation of crystalline phases.

# Composite Glass Seals

Frangible ceramic particles

Multicomponent silicate glass matrix

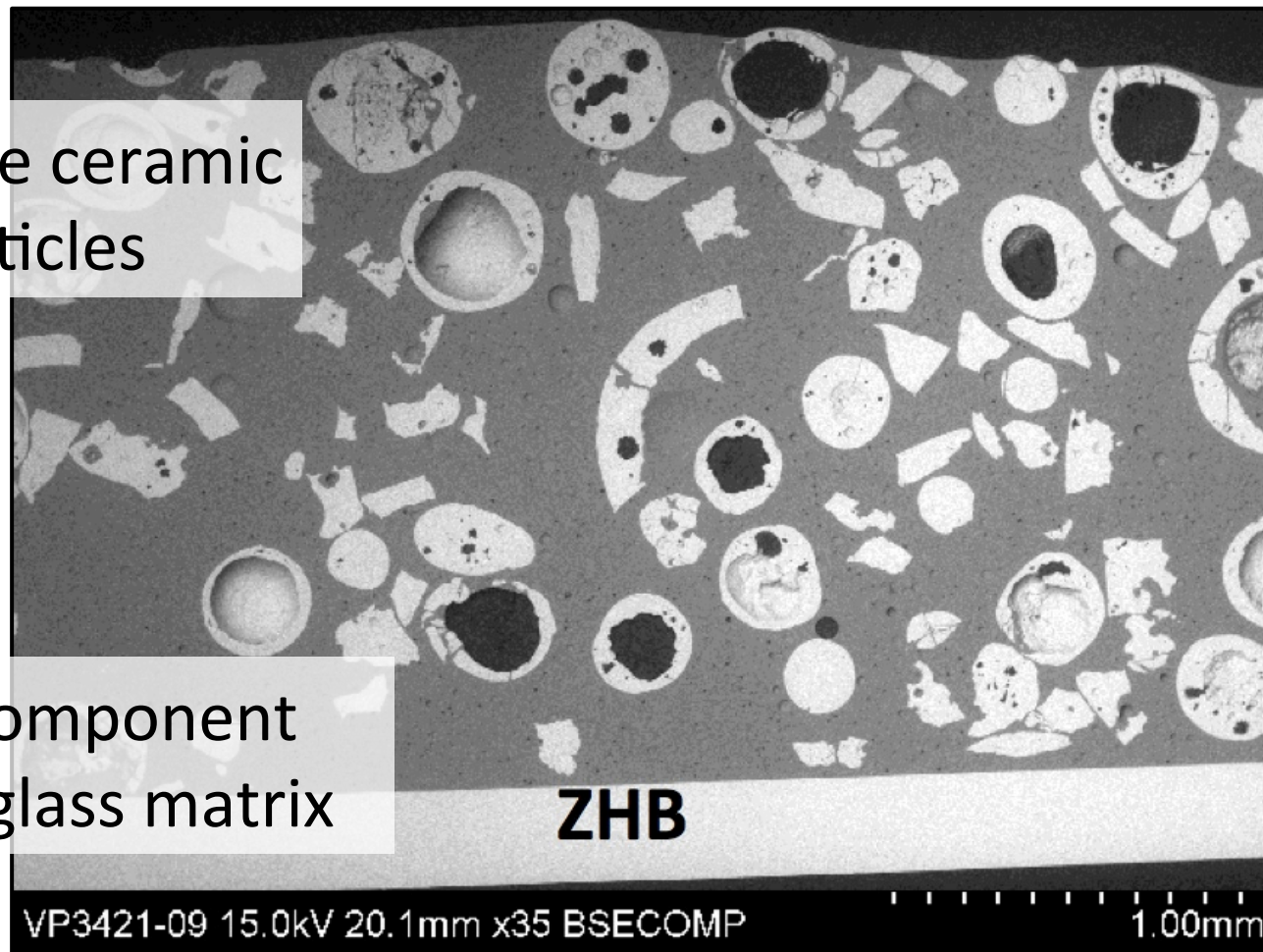

# Composite Glass Seals

zirconia fibers

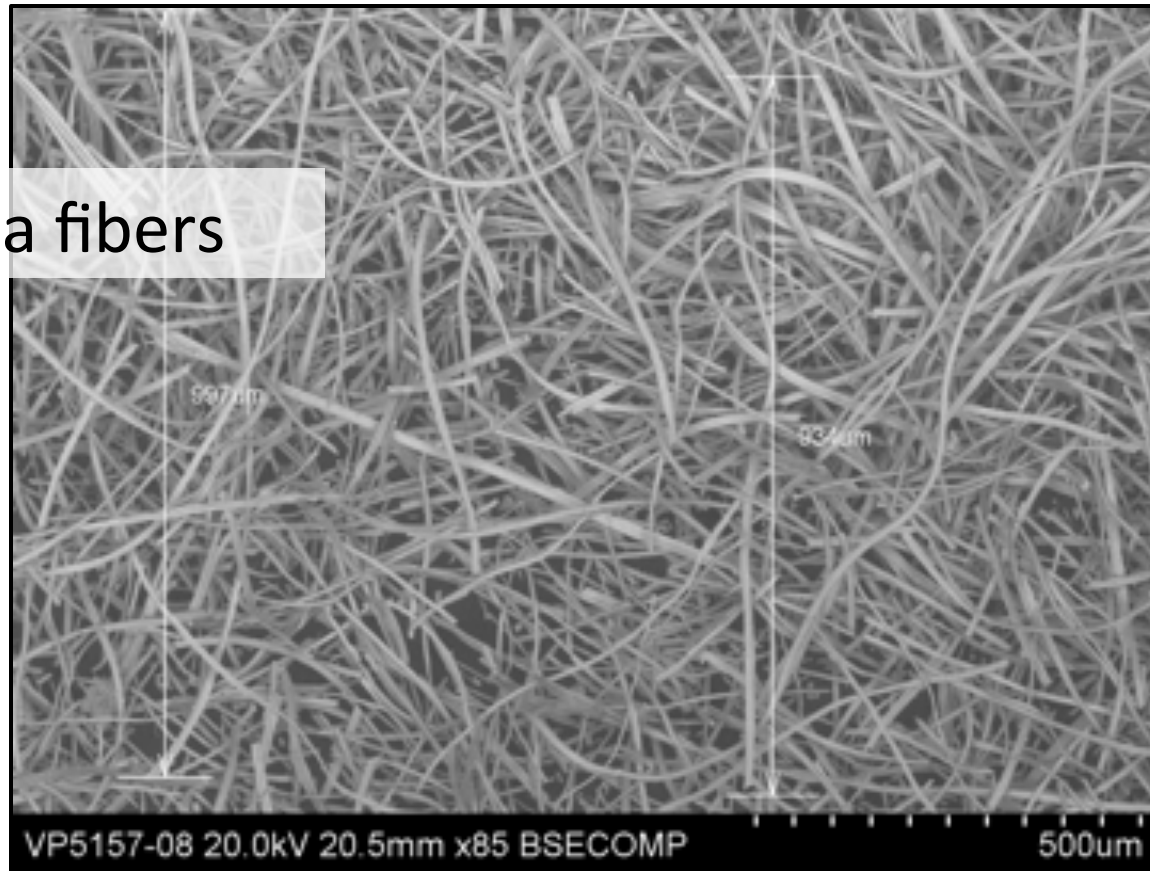

# Wetting Behavior of Composite Glass Seals

**1:1**

**1:2**

**1:3**

**ZHB**

**AgSCO**

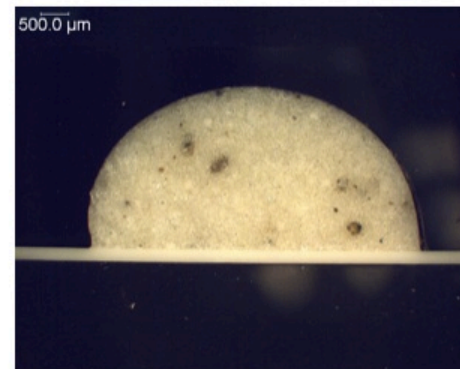
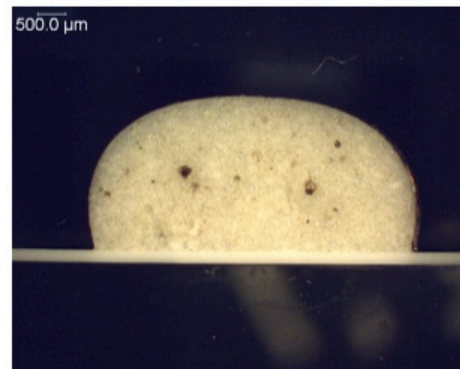
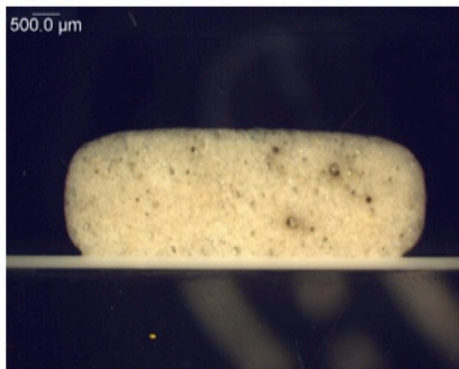
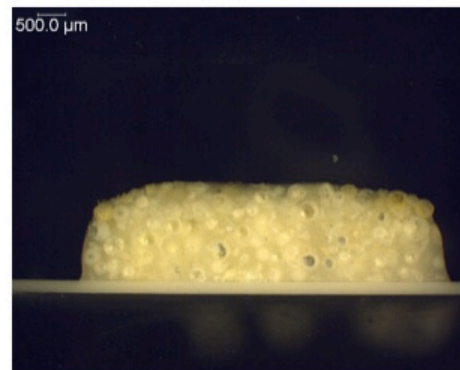
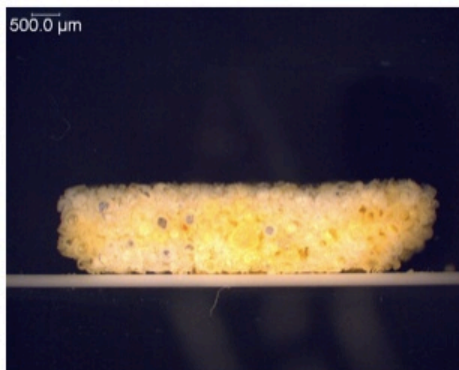

**SCN glass**

# Viscosity of Composite Glass Seals

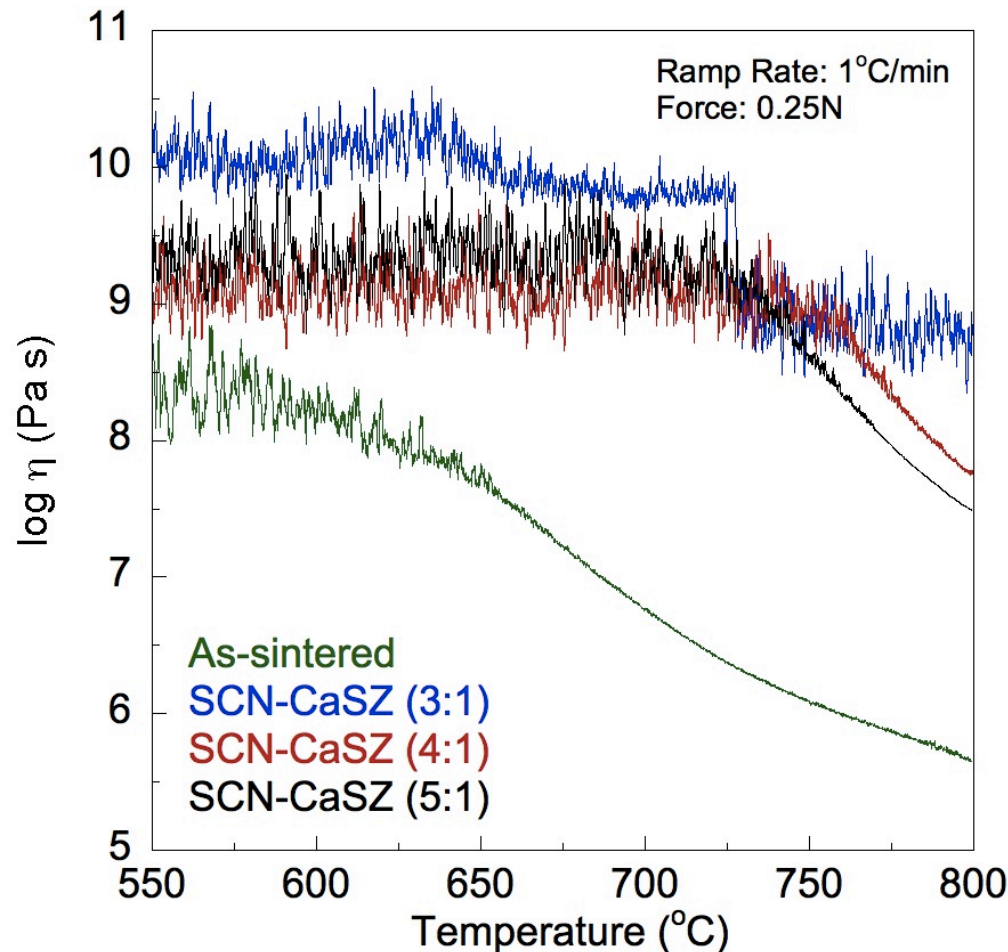

- Viscosity can be tailored by changing the concentration of ceramic particles
- Incorporate data into models to predict time-dependent sealing behavior (PNNL).

# Compliance of Composite Glass Seals

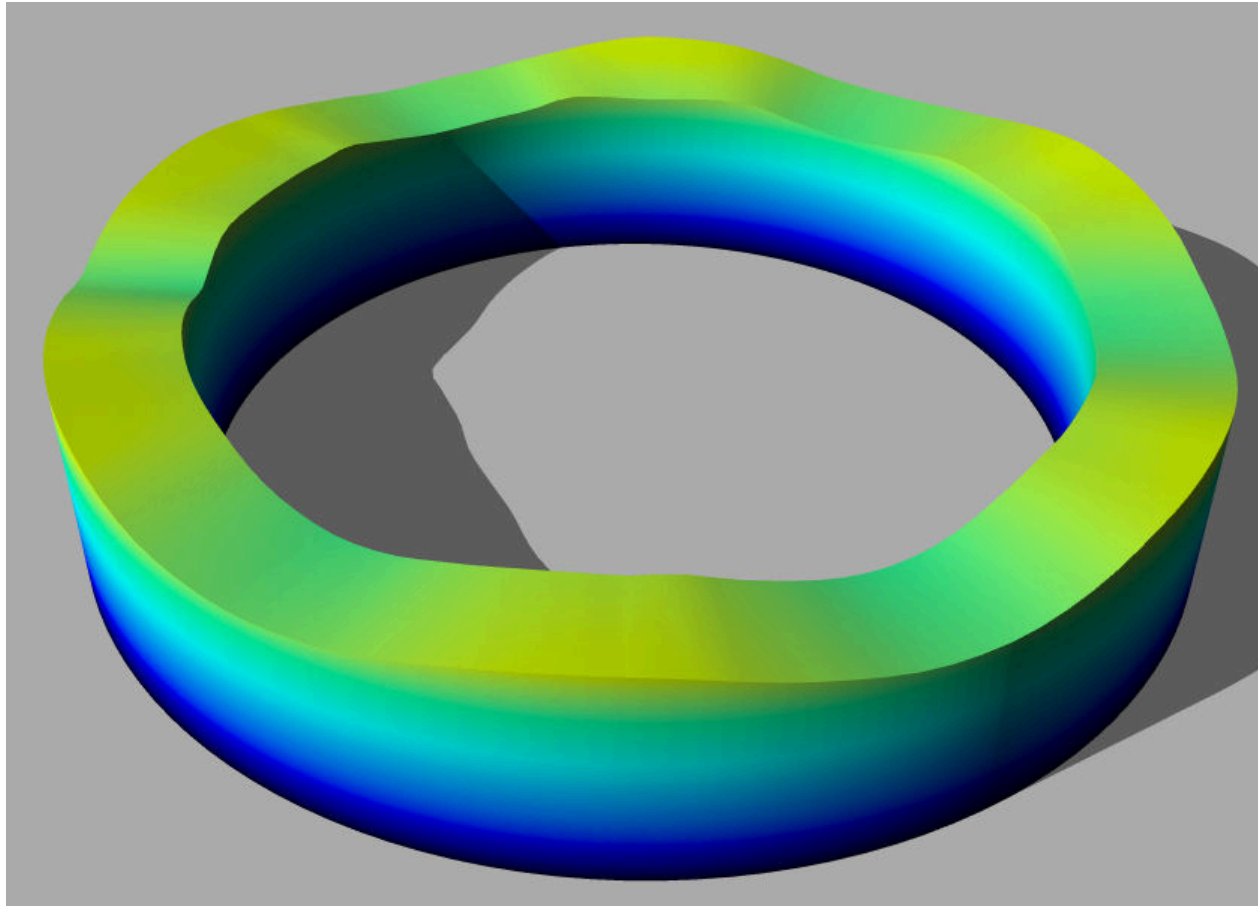



# Compliance of Composite Glass Seals

Zirconia tubes have been bonded to zirconia plates using engineered glass seal. This is the specimen configuration for testing in dual environments

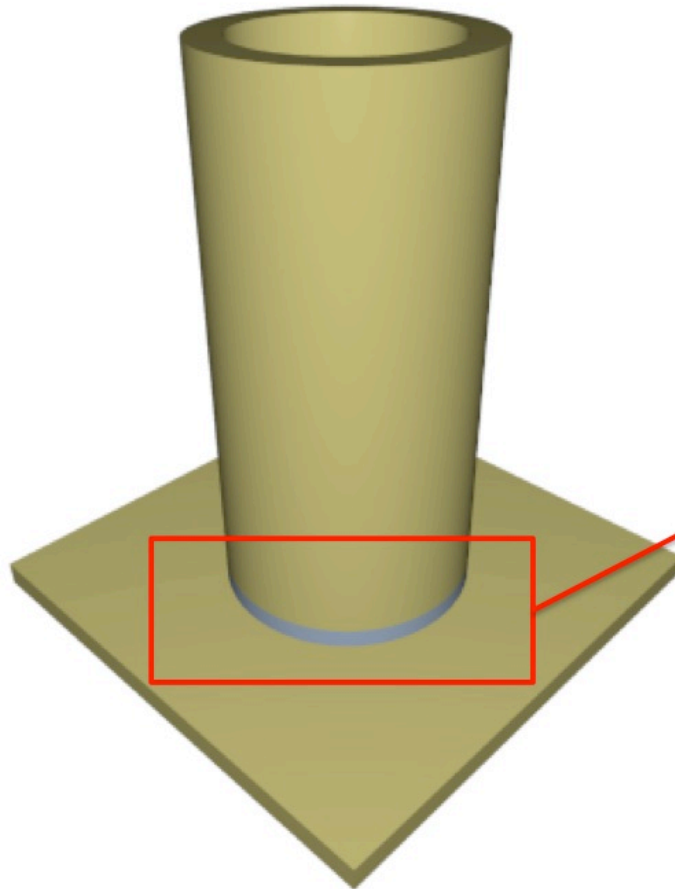

# Evaluation of Seals in Dual Environment

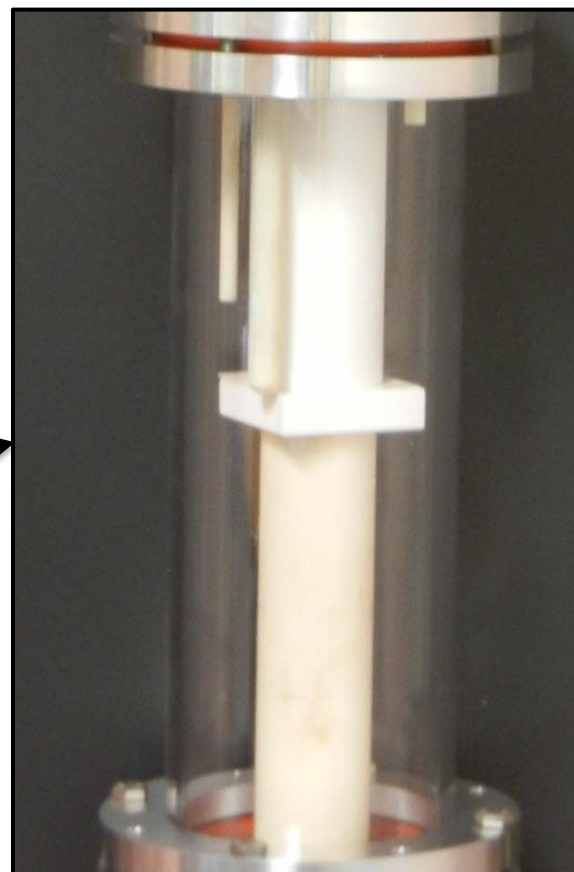
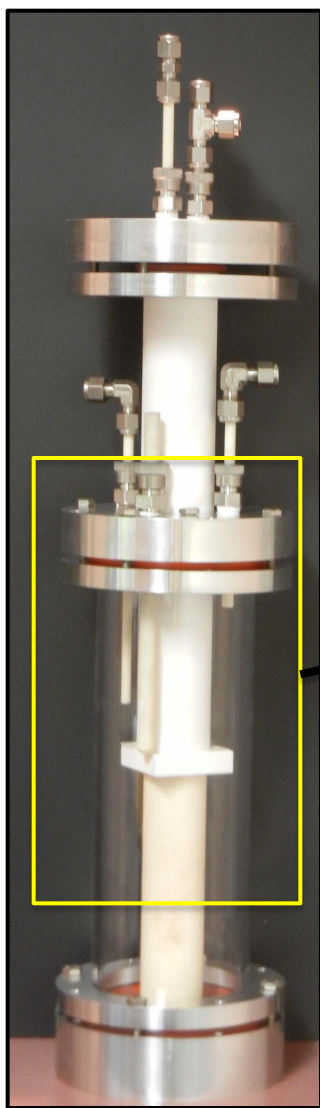

# Compliance of Composite Glass Seals

Zirconia tubes have been bonded to zirconia plates using engineered glass seal. This is the specimen configuration for testing in dual environments

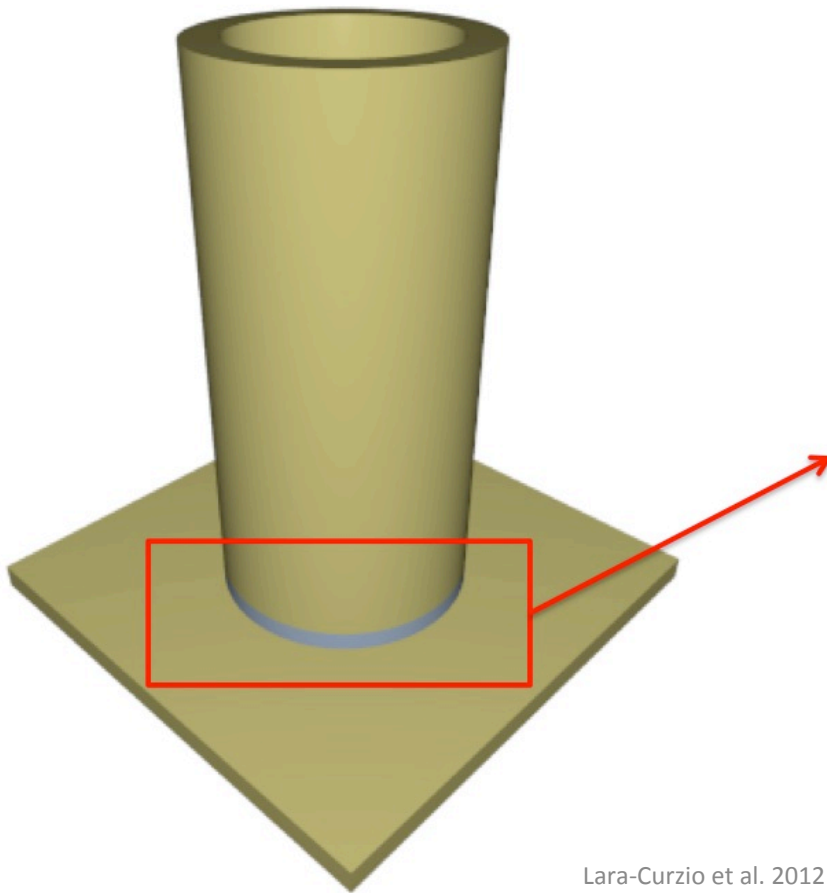

Zirconia tube is cut and ground to enable imaging of bonded area using IR imaging.

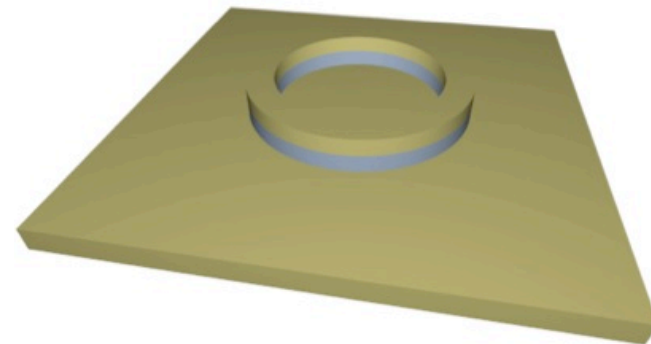

# NDE of composite glass seals

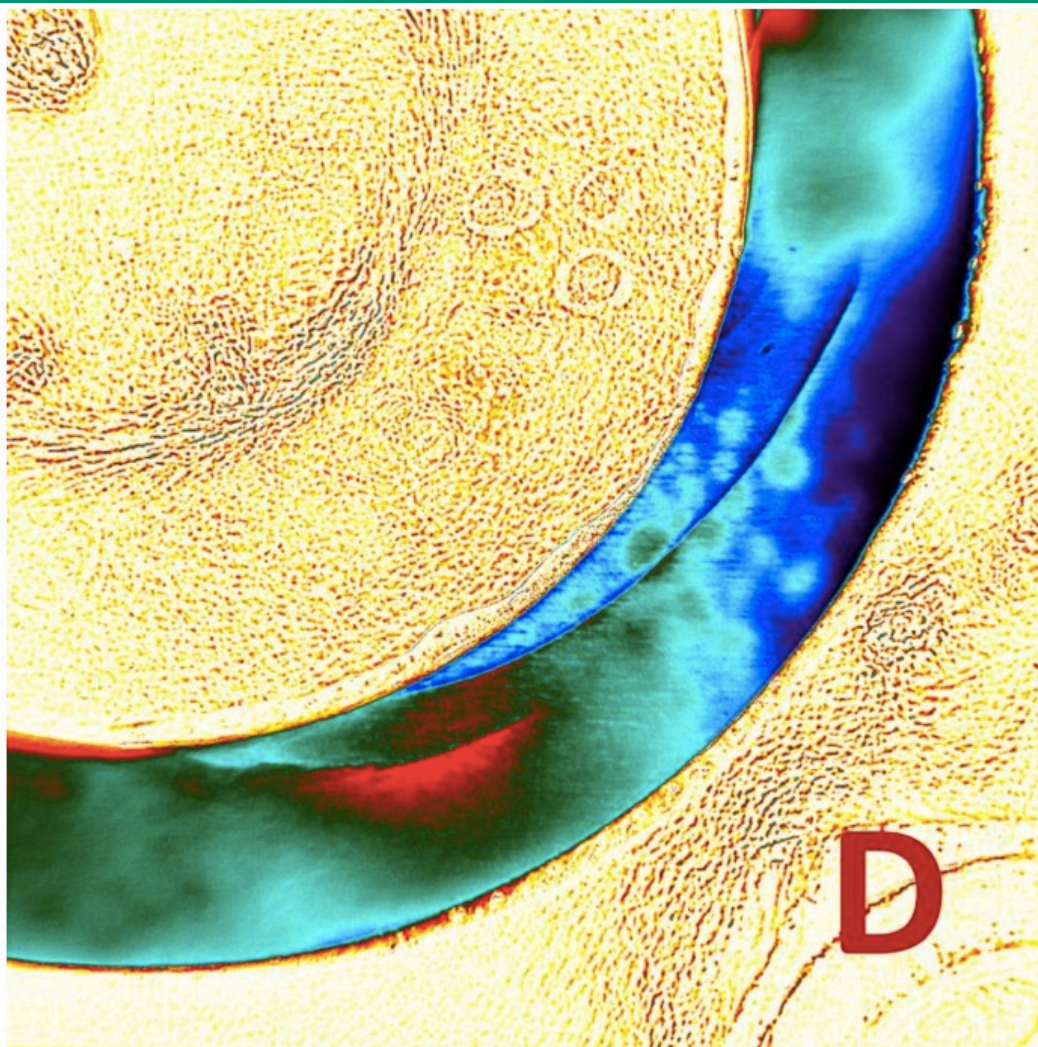
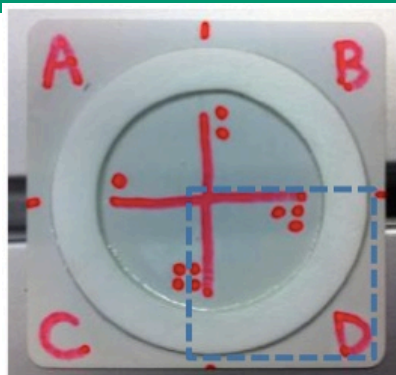

# Fabrication of Composite Glass Seals

Glass-to-particle ratio 3:1

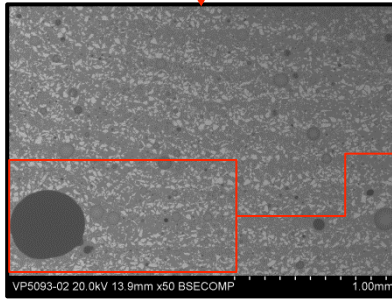
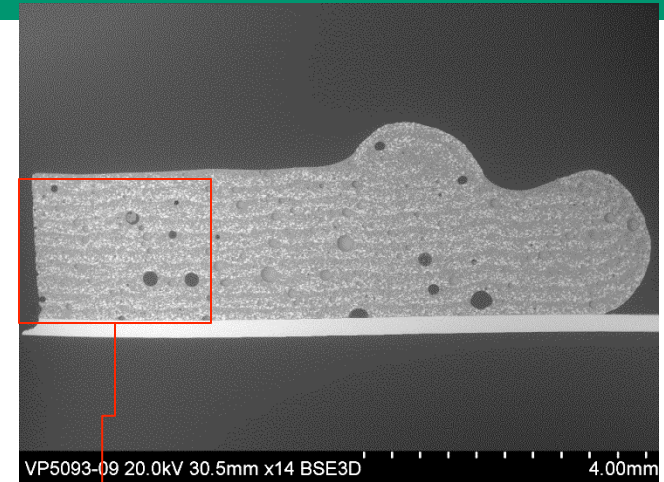
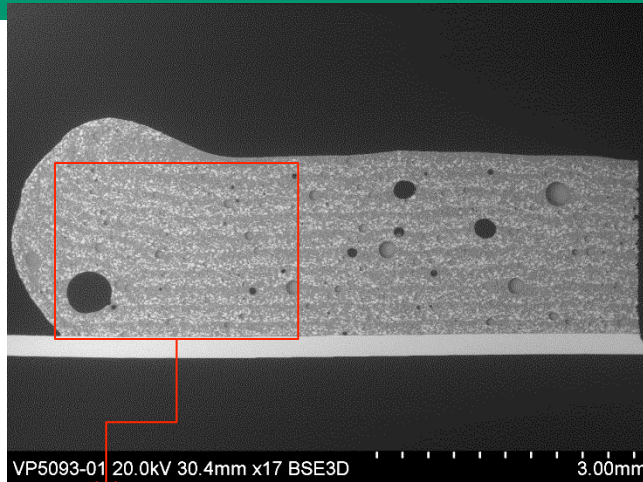

50x

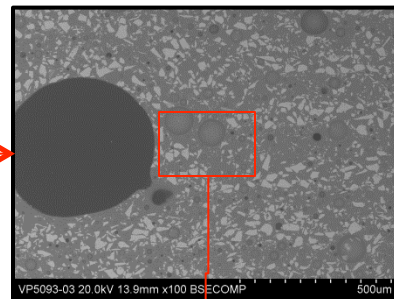

100x

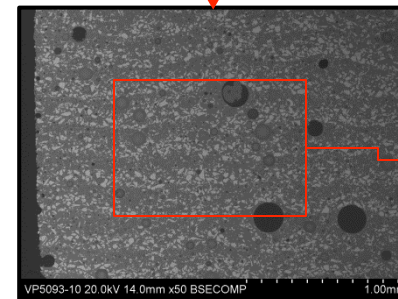

50x

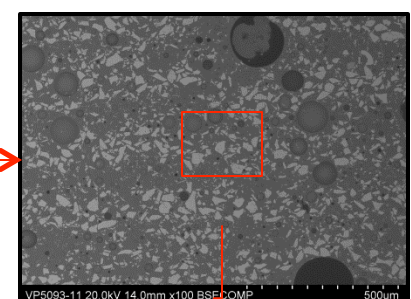

100x

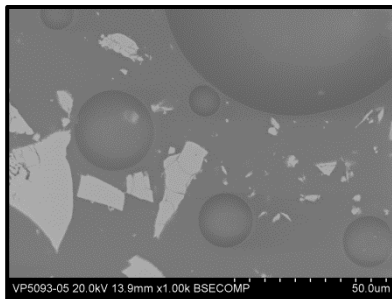

1.0kx

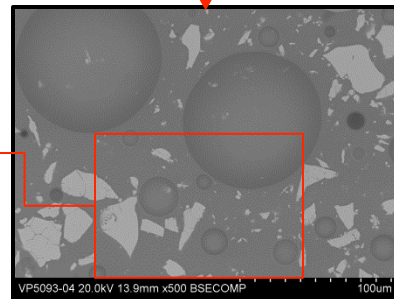

500x

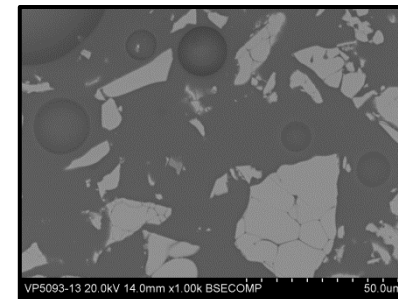

1.0kx

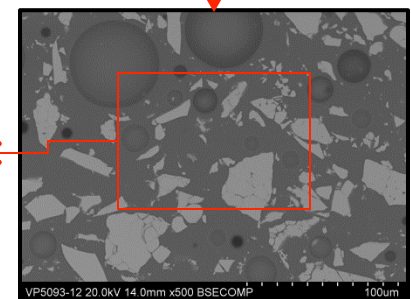

500x

# Fabrication of Composite Glass Seals

Glass-to-bead ratio 5:1

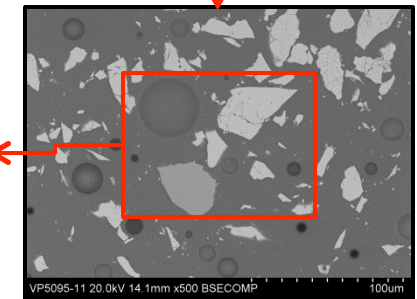
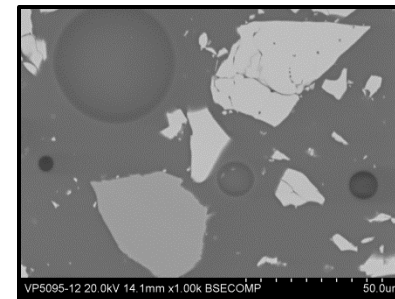
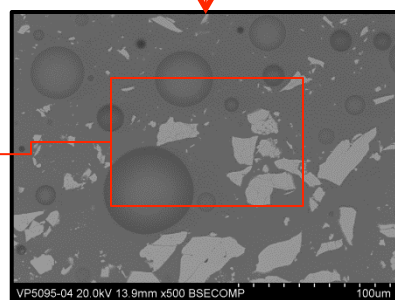
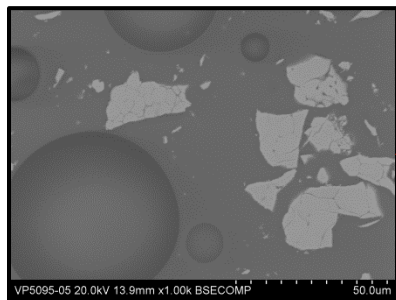
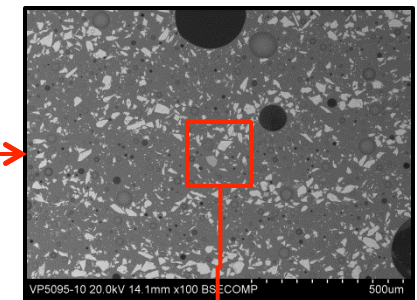
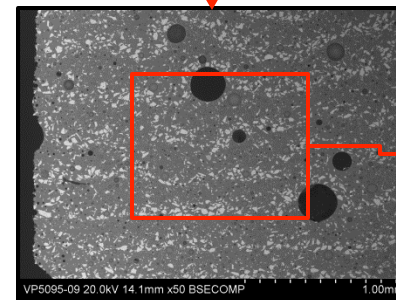
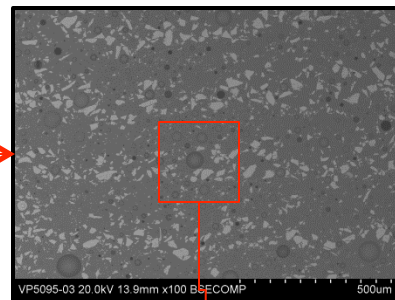
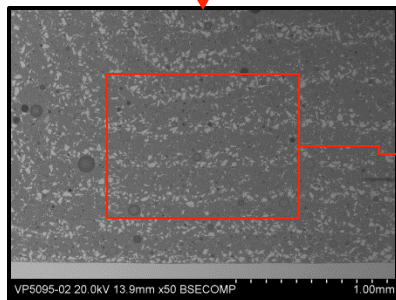
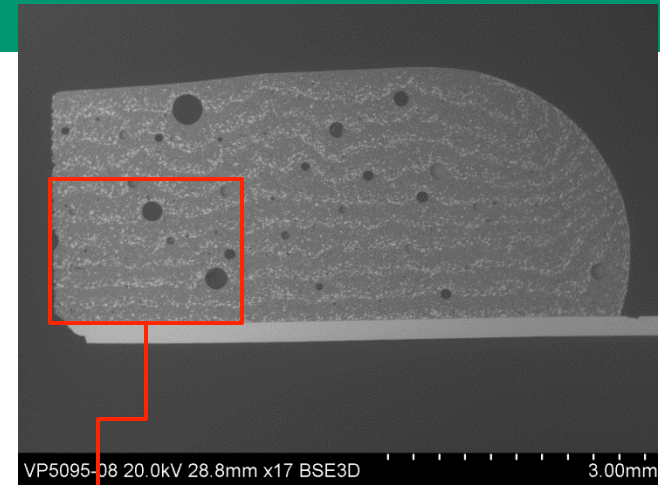
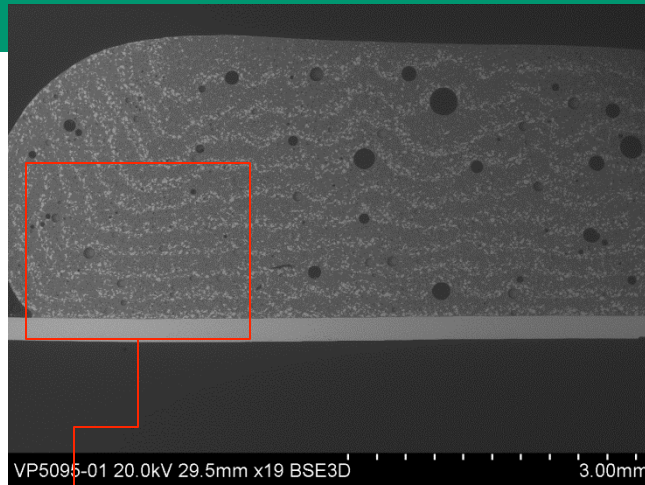

# Summary

- The effect of time of exposure in air and  $H_2+N_2+H_2O$  on the microstructure and physical and mechanical properties of two multicomponent silicate glasses (SCN, G6) have been characterized for up to 10,000 hours.
  - Test specimens continue being exposed (15,000+ hrs).
- Models are being developed to describe the rates of crystallization and the evolution of microstructure and physical properties.

# Summary (cont.)

- Engineering-based models are being developed to predict the behavior of SOFC seals comprising these glasses
- Will continue working with PNNL and SECA industry teams to evaluate composite glass seals in realistic conditions
- Technology transfer